

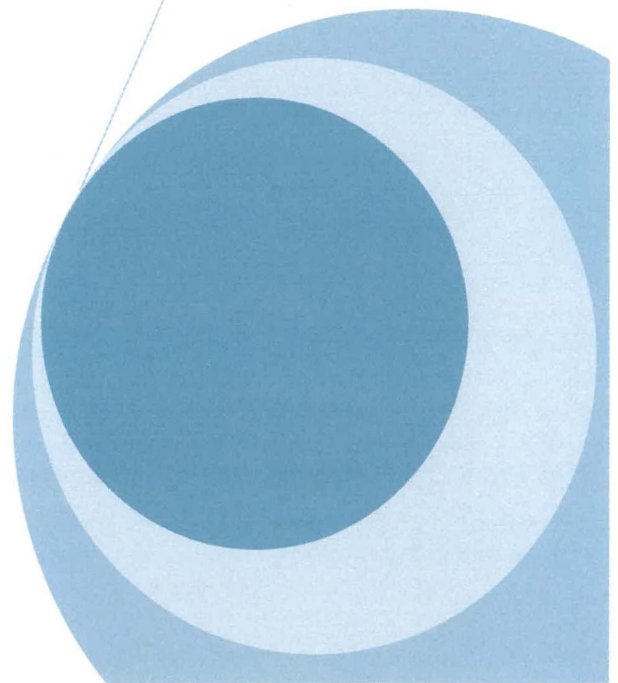

# **Section 600 Roadside Drainage**

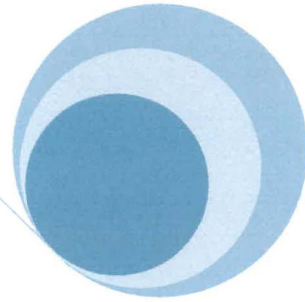
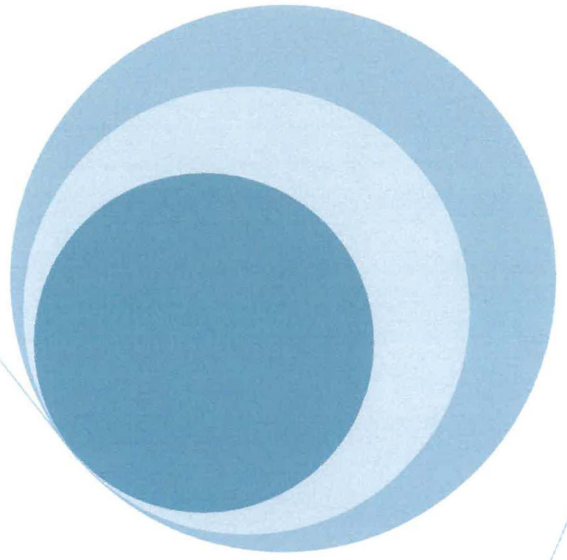

## 600 ROADSIDE DRAINAGE

### 1. Drainage Structure Locations

Storm sewer inlets, manholes, and junction boxes installed along local and residential access streets shall be located adjacent to lot corners, or approximately midway between side lot lines or otherwise placed so as to not conflict or coincide with existing and future construction of driveway connections.

Structures proposed to be located within the pavement area shall be outside the vehicle wheel path.

### 2. Stormwater Service Connections to County Drainage Facilities

The following standards shall apply to the design, construction, and operation of all private stormwater service connections to County maintained roadway drainage systems permitted pursuant to PPM No. EL-O-3601, Right of Way Construction Permit Process and PPM No. EL-O-3604 Stormwater Service Connection to County Drainage Facilities. These publications can be found in the "Policies and Procedures Manual" of the Palm Beach County Department of Engineering and Public Works.

- a. Stormwater service connections shall be permitted only for projects connecting to a County-maintained roadway system for which positive drainage to a point of positive outfall exists. The permitting of the stormwater connection may require construction of all necessary conveyance facilities and establishment of any easements necessary for the operation and maintenance of the drainage facilities, as determined by the County Engineer.
- b. Discharges to County drainage systems shall consist solely of stormwater and shall contain no oil, grease, floating solids, settleable soils, flammable liquids, or domestic or industrial wastewater which would cause or contribute to contravention of State water quality standards in the receiving water bodies.
- c. Onsite stormwater inlets shall include a 2-foot slump at the base to prevent sedimentation downstream.
- d. All discharge structures shall include a baffle system to encourage discharge from the center of the water column rather than the top or bottom. The baffle system shall include a skimmer or other approved mechanism suitable for preventing oil and grease from discharging from retention and detention areas, as required. Any required baffle systems shall be designed so as to not impact the discharge structure's hydraulic capacity.

- e. All discharge to the County right-of-way up to the 25-year / 3-day storm shall be through an approved, onsite control structure with a piped connection to either an adjacent storm sewer or roadside drainage ditch.
- f. No discharge of stormwater runoff to roadside swales by overland flow, open channel flow or pipe connection shall be permitted. This prohibition includes the use of "bubble-up" structures.
- g. Unless the permittee provides satisfactory evidence of a specific allocation of discharge from the lot in the County-approved design of an existing roadway drainage system, the following onsite storage requirements and discharge limits shall apply:
  - i. The peak discharge rate from the 3-year / 24-hour storm shall not exceed the existing peak discharge to the right-of-way. The peak discharge shall be based upon the total site area and shall be based upon an assumed tailwater elevation equal to the static water surface elevation (i.e. elevation at zero inflow) in the roadway storm sewer at the point of connection;
  - ii. The peak discharge rate for the 25-year / 3-day storm shall not exceed the lesser of the existing peak discharge from the total site area for the same storm or the allowable peak discharge rate established by the agency with jurisdiction over the receiving water body providing outfall to the County roadway drainage system. The discharge rate shall be based upon a tailwater elevation equal to the static water surface elevation (i.e. elevation at zero inflow) in the roadway storm sewer at the point of connection;
  - iii. The onsite peak elevation due to a 3-year / 24-hour storm shall be no higher than the design hydraulic grade line elevation of the roadway system for the same storm, at the point of connection.
  - iv. Where design information is not available from the Department of Engineering and Public Works Roadway Production Division for a particular reach of storm sewer at the point of connection, the design hydraulic grade line shall be assumed to be 1-foot below the inlet (grate or throat) elevation of the inlet structure immediately upstream from the point of connection;
  - v. The proposed stormwater management system shall be designed to recover the runoff volume generated by the 25-year / 3-day storm event within 5 days after the cessation of the storm event. Unless otherwise dictated by a drainage district having authority over the site, the system

shall also be designed to recover the required water quality volume within 3 days after the cessation of a storm event.

- h. Connections to County maintained roadway drainage systems shall be located within the limits of the lot frontage unless either:
  - i. an appropriate drainage easement is obtained (outside of the right-of-way) to allow storm water runoff to be discharged to an alternative point of connection; or
  - ii. the proposed connection to the County maintained roadway drainage is sized adequately to accommodate all possible inflows to the public right-of-way, as determined by the County Engineer.
- i. The connection of two or more outfall pipes to create a single connection to the right-of-way shall require a manhole, junction box, or other structure for visual observation of each individual discharge. Said structure shall be installed outside the right-of-way at a location easily accessible to County personnel for inspection at any time.
- j. Connections to a County maintained roadway drainage system should be to an existing drainage structure, where possible. If no structure exists in the area for the point of connection, then a structure may be constructed by the permittee if approval is received by the County Engineer.
- k. Piped connections to an existing roadside ditch shall be made using a suitable endwall and erosion protection for the side slopes and invert of the ditch, subject to approval by the County Engineer. Outfalls shall not protrude into the design cross-section of the ditch, and shall not be recessed into the side slope in a manner that will create eddys, bank sloughing, shoaling, or otherwise interfere with longitudinal flow or normal ditch maintenance.
- l. Discharge pipe installed within the County right-of-way shall have a minimum of 3-feet of cover to the finished grade, unless otherwise approved by the County Engineer. A hydraulically equivalent elliptical reinforced concrete pipe may be utilized to avoid potential pipe cover issues.

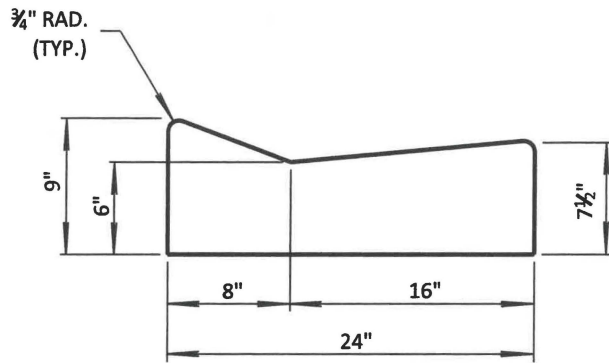

2' VALLEY GUTTER -  
NON-SYMMETRICAL  
(a/k/a MIAMI CURB)

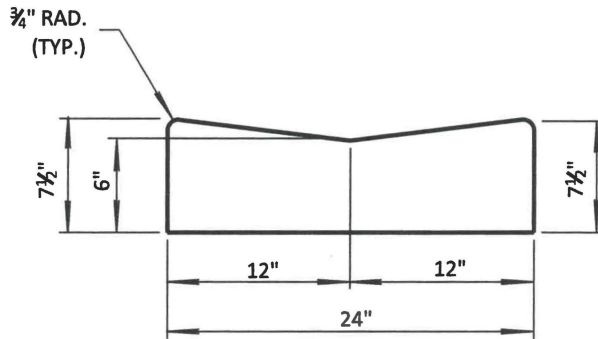

2' VALLEY GUTTER -  
SYMMETRICAL

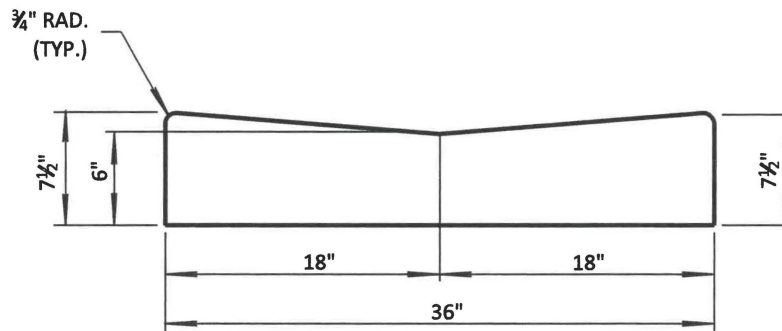

3' VALLEY GUTTER

FILEPATH: P:/DGN/ENG SER/LAND DEVELOPMENT STANDARDS/DWF FORMAT/600.1

PALM BEACH COUNTY DEPARTMENT OF ENGINEERING & PUBLIC WORKS				VALLEY GUTTERS		DRAWING NO.
DRAWN BY:	DATE:	REVISED BY:	DATE:	APPROVED:	EFFECTIVE:	600.1
K.L.	05/23/90	J.M.K.	02/01/2018	<i>[Signature]</i>	2/9/18	
				COUNTY ENGINEER OR DESIGNEE		

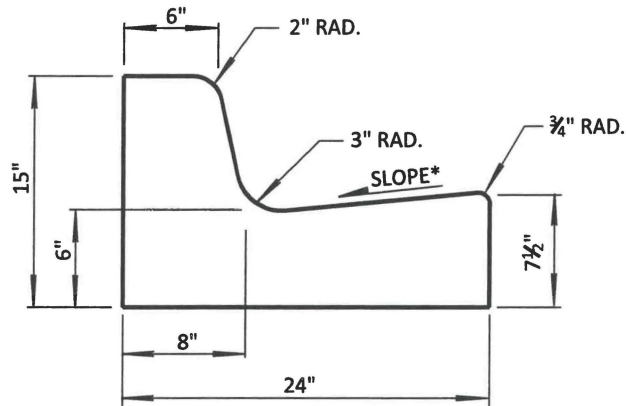

**BARRIER CURB & GUTTER**

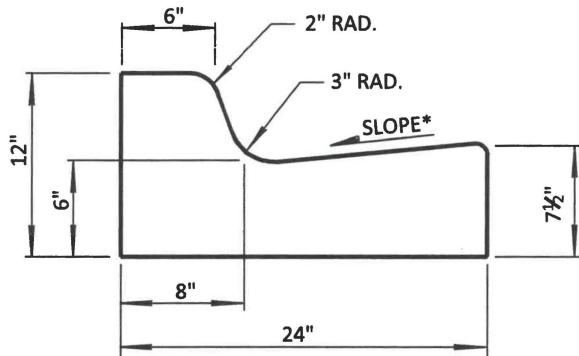

**VERTICAL CURB & GUTTER**

\* **NOTE:** WHEN USED ON HIGH SIDE OF ROADWAYS, THE CROSS SLOPE OF THE GUTTER SHALL MATCH THE CROSS SLOPE OF THE ADJACENT PAVEMENT AND THE THICKNESS OF THE LIP SHALL BE 6 INCHES.

FILEPATH: P:/DGN/ENG SER/LAND DEVELOPMENT STANDARDS/DWF FORMAT/600.2

PALM BEACH COUNTY DEPARTMENT OF ENGINEERING & PUBLIC WORKS				NON-MOUNTABLE CURB & GUTTER		DRAWING NO.
DRAWN BY:	DATE:	REVISED BY:	DATE:	APPROVED:	EFFECTIVE:	600.2
K.L.	05/23/90	J.M.K.	02/01/2018	<i>[Signature]</i>	01/11/18	
				COUNTY ENGINEER OR DESIGNEE		

#4 BAR PLACED  
ON PAVEMENT SIDE

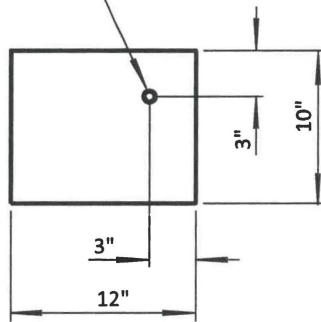

FILEPATH: P:/DGN/ENG SER/LAND DEVELOPMENT STANDARDS/DWF FORMAT/600.3

PALM BEACH COUNTY DEPARTMENT OF ENGINEERING & PUBLIC WORKS				FLUSH HEADER CURB		DRAWING NO.  600.3
DRAWN BY:	DATE:	REVISED BY:	DATE:	APPROVED:	EFFECTIVE:	
K.L.	05/23/90	J.M.K.	02/01/2018	<i>John A. Donnell</i>	2/19/18	
				COUNTY ENGINEER OR DESIGNEE		

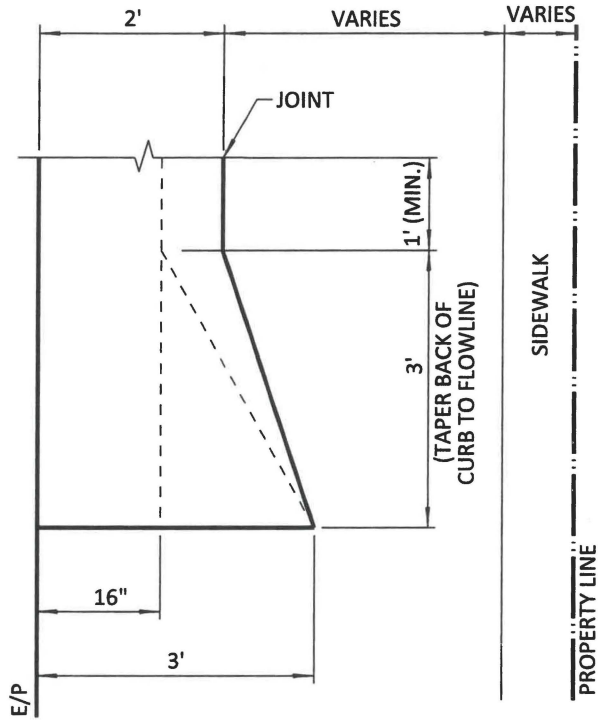

**PLAN  
NON-SYMMETRICAL  
VALLEY GUTTER**

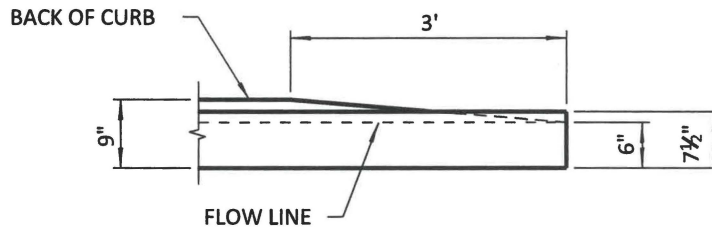

**PROFILE**

FILEPATH: P:/DGN/ENG SER/LAND DEVELOPMENT STANDARDS/DWF FORMAT/600.4

<b>PALM BEACH COUNTY DEPARTMENT OF ENGINEERING &amp; PUBLIC WORKS</b>				<b>CONCRETE TRANSITION END (VALLEY GUTTER TO SWALE)</b>		DRAWING NO.
DRAWN BY:	DATE:	REVISED BY:	DATE:	APPROVED:	EFFECTIVE:	600.4
K.L.	05/23/90	J.M.K.	02/01/2018	<i>[Signature]</i>	2/9/18	
				COUNTY ENGINEER OR DESIGNEE		



SEED & MULCH ON COMPACTED SHOULDER TO PATHWAY OR PROPERTY LINE, STABILIZED AS NEEDED TO MIN. FBV OF 50 P.S.I. (6" DEPTH)

OR

FULL SOD ON COMPACTED SHOULDER TO PATHWAY OR PROPERTY LINE.

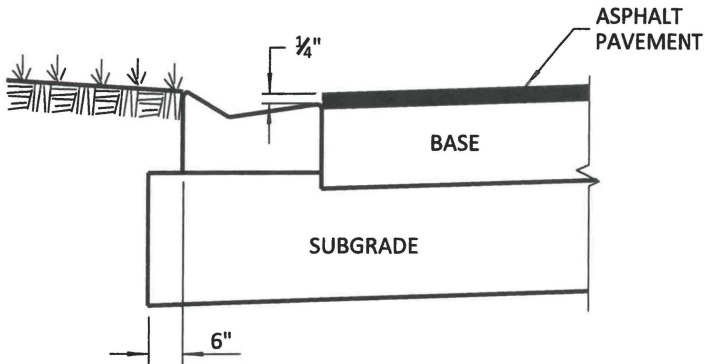

**VALLEY GUTTERS**

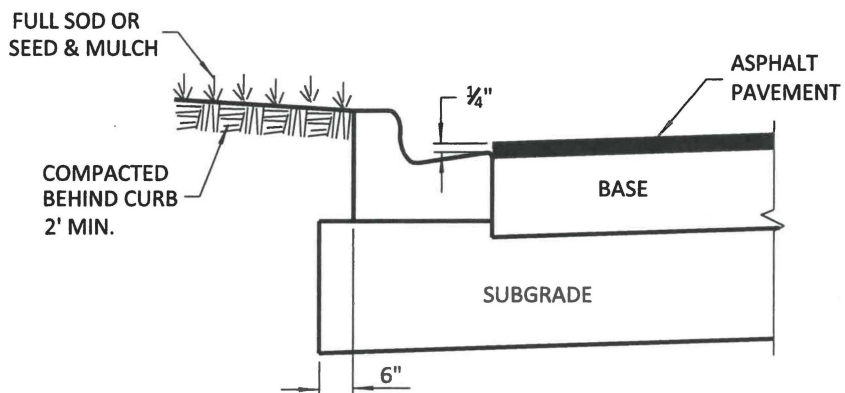

**NON-MOUNTABLE CURB & GUTTERS**

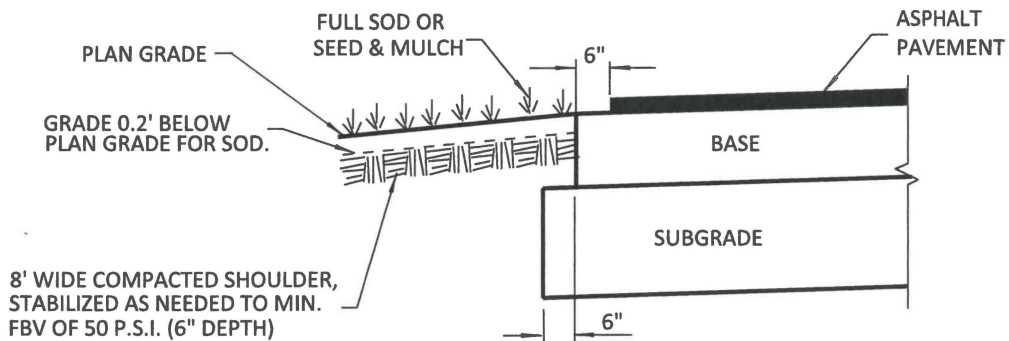

**SWALE**

FILEPATH: P:/DGN/ENG SER/LAND DEVELOPMENT STANDARDS/DWF FORMAT/600.5A

<b>PALM BEACH COUNTY DEPARTMENT OF ENGINEERING &amp; PUBLIC WORKS</b>				<b>LOCAL STREET PAVEMENT EDGE DETAILS</b>		DRAWING NO.	
						600.5A	
DRAWN BY: K.L.	DATE: 05/23/90	REVISED BY: J.M.K.	DATE: 02/01/2018	APPROVED:  COUNTY ENGINEER OR DESIGNEE	EFFECTIVE: 2/9/18		

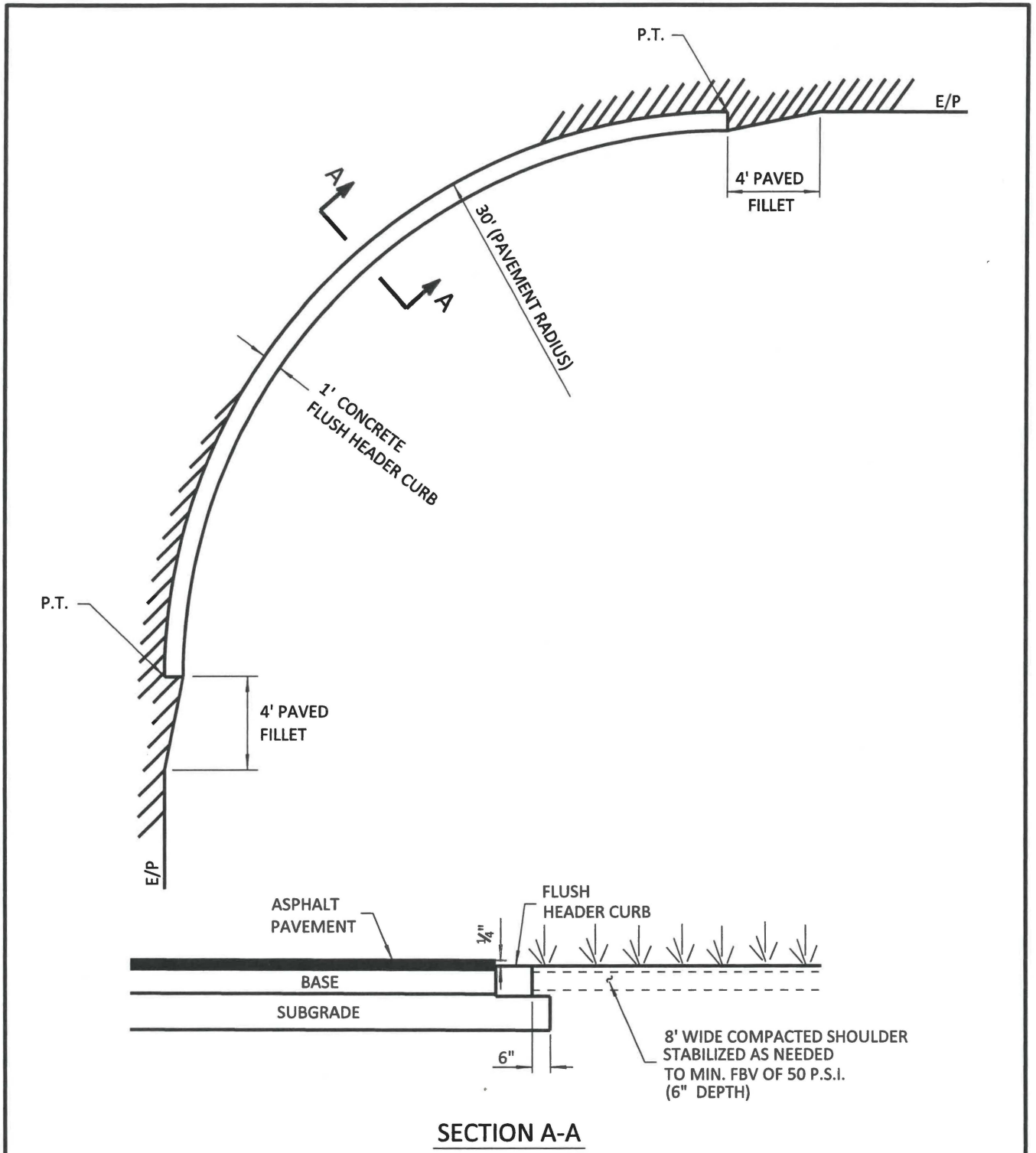

**SECTION A-A**

FILEPATH: P:/DGN/ENG SER/LAND DEVELOPMENT STANDARDS/DWF FORMAT/600.5B

<b>PALM BEACH COUNTY DEPARTMENT OF ENGINEERING &amp; PUBLIC WORKS</b>				<b>LOCAL STREET PAVEMENT EDGE DETAILS FLUSH HEADER CURB</b>		<b>DRAWING NO.  600.5B</b>

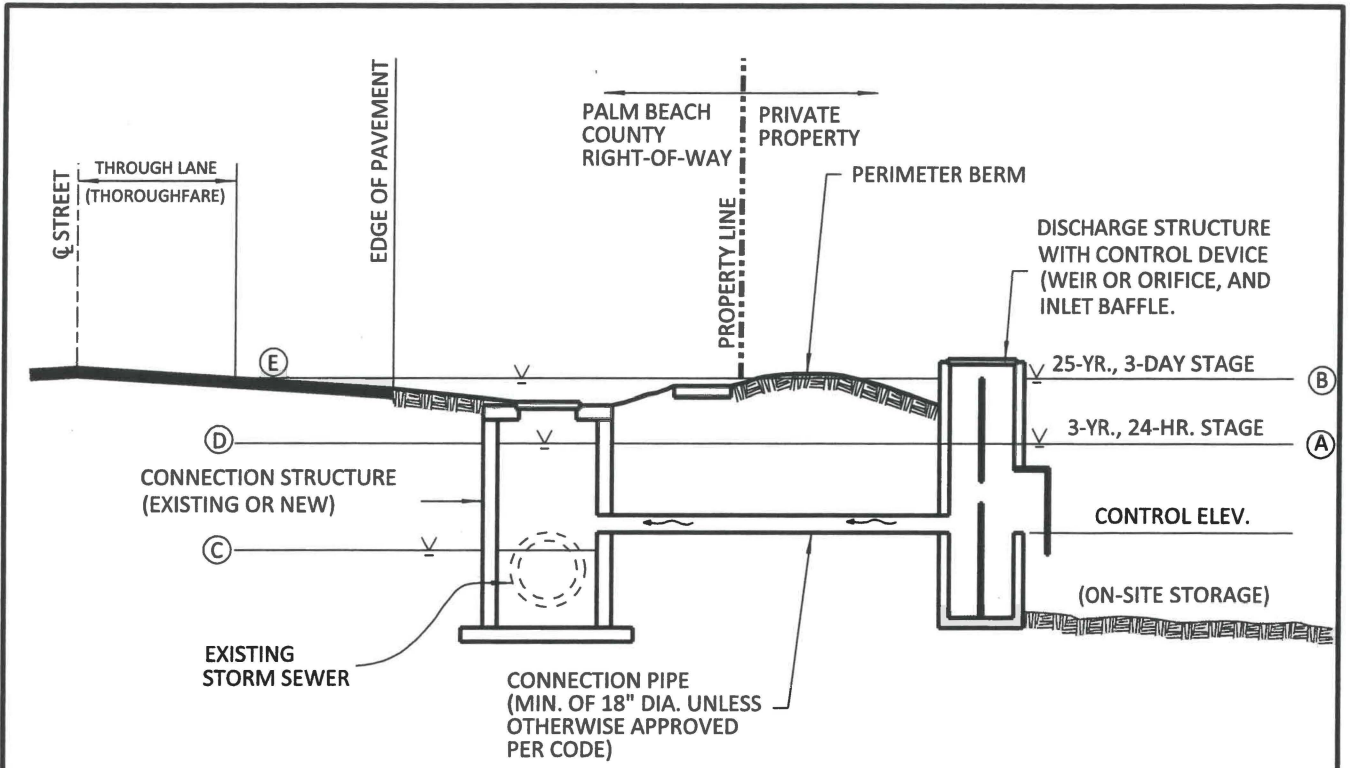

- (A) PEAK ON-SITE STORAGE ELEVATION WITH RUNOFF PRODUCED BY 3-YR., 24-HR. RAINFALL FROM TOTAL AREA DRAINED BY SERVICE CONNECTION, NOT TO EXCEED HYDRAULIC GRADE LINE (H.G.L.) ELEVATION AS NOTED IN (D)
- (B) PEAK ON-SITE STORAGE ELEVATION WITH RUNOFF PRODUCED BY 25-YR., 3-DAY RAINFALL, NOT TO EXCEED LOWER OF SITE PERIMETER BERM ELEVATION OR (FOR THOROUGHFARE-PLAN STREETS) PAVEMENT ELEVATION AS NOTED IN (E)
- (C) STORM SEWER H.G.L. ELEVATION AT ZERO FLOW IN RECEIVING SEWER (i.e, TAILWATER ELEVATION TO BE USED FOR DETERMINING STAGE VS. DISCHARGE OF CONTROL DEVICE)
- (D) STORM SEWER H.G.L. ELEVATION AT DESIGN PEAK FLOW AT POINT OF CONNECTION. IF NOT OTHERWISE KNOWN, USE 1 FT. BELOW INLET ELEVATION OF NEXT UPSTREAM ON-LINE INLET.
- (E) PAVEMENT ELEVATION AT OUTSIDE EDGE OF HIGHEST THROUGH LANES (ONE IN EACH DIRECTION) FOR THOROUGHFARE-PLAN STREET.

FILEPATH: P:/DGN/ENG SER/LAND DEVELOPMENT STANDARDS/DWF FORMAT/600.6

PALM BEACH COUNTY DEPARTMENT OF ENGINEERING & PUBLIC WORKS				STORM WATER CONNECTION TO COUNTY STORM SEWER (HYDRAULIC DESIGN SCHEMATIC)		DRAWING NO.  600.6
DRAWN BY:  K.L.	DATE:  06/17/91	REVISED BY: J.M.K.	DATE: 02/01/2018	APPROVED:  <i>[Signature]</i> COUNTY ENGINEER OF DESIGNEE	EFFECTIVE:  2/1/18	