

Project Entrance Sign

N.T.S.

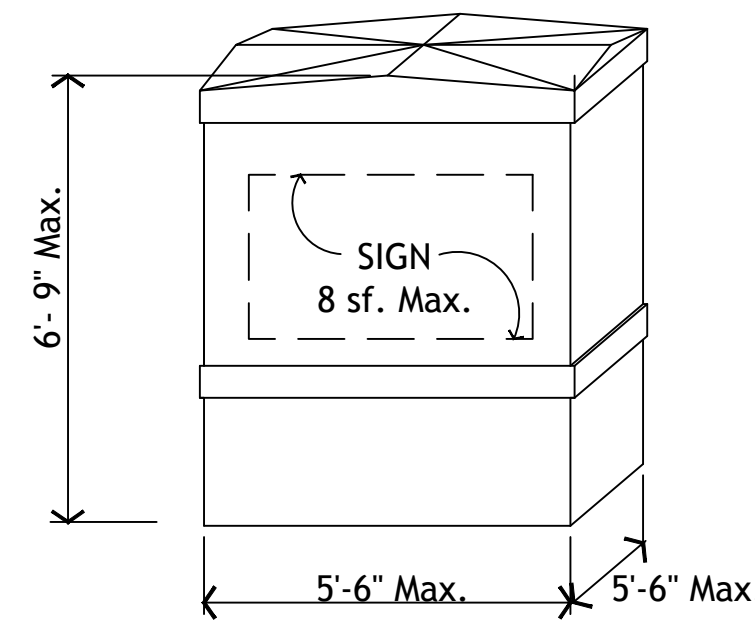

On-POD Directional Sign (Pod Entry Sign)

N.T.S.

PROJECT IDENTIFICATION SIGN - MONUMENT TYPE - SINGLE FACE PERMITTED
 MAXIMUM SIGN AREA - 24 SF.
 MAXIMUM HEIGHT - 6'
 MINIMUM SETBACK - 10'

NOTE:
 PER ULDC TABLE 8.G.3.E.-14 IF A DECORATIVE BACKGROUND ELEMENT SUCH AS TILE, STUCCO OR OTHER BUILDING MATERIAL OR COLOR IS USED, THE MAXIMUM SIGN FACE AREA FOR SUCH DECORATIVE TREATMENT MAY BE EXPANDED 24 INCHES, MEASURED FROM THE SIGN FACE AREA IN EACH CARDINAL DIRECTION.



Project Identification Sign - Property corners

NTS

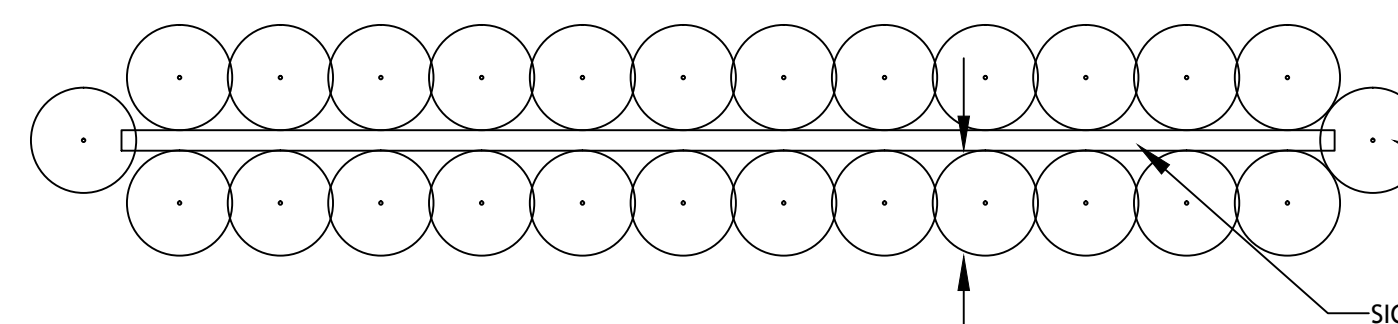

Typical Sign Foundation Planting Detail

NTS

| Indian Trails Grove - Master Sign Plan | | |
|---|--|---|
| Entrance Signs - Art. 8.G.2.C | | |
| | Permitted | Provided |
| Max. No. | 2 per entrance | 2 for every entrance from exterior roads (Total number to be determined) |
| Sign Face | 60 SF | 60 SF |
| Max. Ht. | 8 feet | 8 feet |
| Add. Ht. Option | Max. sign height, excluding height of structure to which the sign is attached may be increased up to 10' for a RW greater than 80' or up to 110', or 12' for a RW greater than 110'. Subject to a 25' setback. | to be determined |
| Setback | 25 feet if added height | 25 feet |
| Location | Within 100 feet of entrance | Within 100 feet of entrance |
| On-site Directional Signs - Art. 8.G.3.D | | |
| | Permitted | Provided |
| Max. No. | N/A | At entrances to Pods; within all Civic Pods; Commercial Pod and Private Recreation |
| Sign Face | 24 SF | Up to 24 SF |
| Max. Ht. | 7 feet | Up to 7 feet |
| Project ID Sign - Art.8 - Table 8.G.3.E | | |
| | Permitted | Provided |
| Max. No. | 2 per road frontage with PUD access | Min. 6 (2 on 180th Avenue; 2 on 190th Avenue and 2 on 59th Lane North) and 1 at each Private Recreation Pod |
| Sign Face | 24 SF | 24 SF |
| Max. Ht. | 6 feet | 6 feet |
| Min. Setback | 10 feet | 10 feet |

PALM BEACH WEST ASSOCIATES I, LLLP
 1600 SAWGRASS CORPORATE PKWY
 SUITE 400
 SUNRISE, FLORIDA 33323
 954-753-1730

Consultants:
CIVIL ENGINEER
 GLH Engineering, LLC
 1600 Sawgrass Corporate Pkwy
 Suite 400
 Sunrise, FL 33323
 954-753-1730
SURVEYOR
 Sand and Hills Survey, Inc.
 8461 Lake Worth Road, Suite 410
 Lake Worth, FL 33467
 (561) 209-6048
TRAFFIC ENGINEER
 Simmons and White
 2581 Metrocentre Blvd. Suite 3
 West Palm Beach, FL 33407
 (561) 478-7848
PLANNERS
 Urban Design Kilday Studios
 610 Clematis Street, Suite CU02
 West Palm Beach, FL 33401
 (561) 366-1100

Project:
INDIAN TRAILS GROVE - PUD

Palm Beach County, Florida

Sheet title:
PRELIMINARY Master Sign Plan

Date:
2015-07-15

Revisions:
 2015-09-28 Resubmittal

Amendments:

Zoning Stamps:

Sheet number:

PMSP-1