

5149.001

HIPPOCRATES PUD/CLF

BEING A REPLAT OF HIPPOCRATES HEALTH INSTITUTE, ACCORDING TO THE PLAT THEREOF, ON FILE IN THE OFFICE OF THE CLERK OF THE CIRCUIT COURT IN AND FOR PALM BEACH COUNTY, FLORIDA, RECORDED IN PLAT BOOK 104, PAGES 118 AND 119, AND A REPLAT OF A PORTION OF TRACT 7, BLOCK 3, PALM BEACH FARMS COMPANY PLAT NO. 3, ACCORDING TO THE PLAT THEREOF, ON FILE IN THE OFFICE OF THE CLERK OF THE CIRCUIT COURT IN AND FOR PALM BEACH COUNTY, FLORIDA, RECORDED IN PLAT BOOK 2, PAGES 45 TO 54, LYING IN SECTION 28, TOWNSHIP 43 SOUTH, RANGE 42 EAST, PALM BEACH COUNTY, FLORIDA. JANUARY, 2012

NOTE
IN THOSE CASES WHERE EASEMENTS OF DIFFERENT TYPES CROSS OR OTHERWISE COINCIDE, DRAINAGE EASEMENTS SHALL HAVE FIRST PRIORITY, UTILITY EASEMENTS SHALL HAVE SECOND PRIORITY, ACCESS EASEMENTS SHALL HAVE THIRD PRIORITY, AND ALL OTHER EASEMENTS SHALL BE SUBORDINATE TO THESE WITH THEIR PRIORITIES BEING DETERMINED BY USE RIGHTS GRANTED.

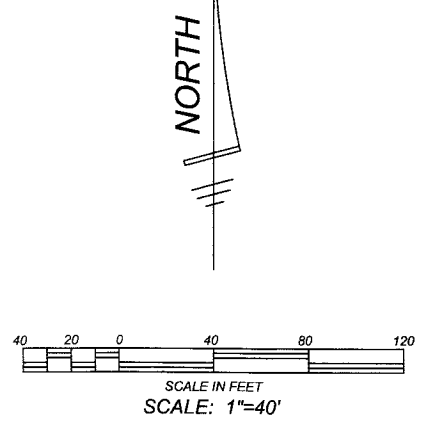

SHEET 4 OF 6

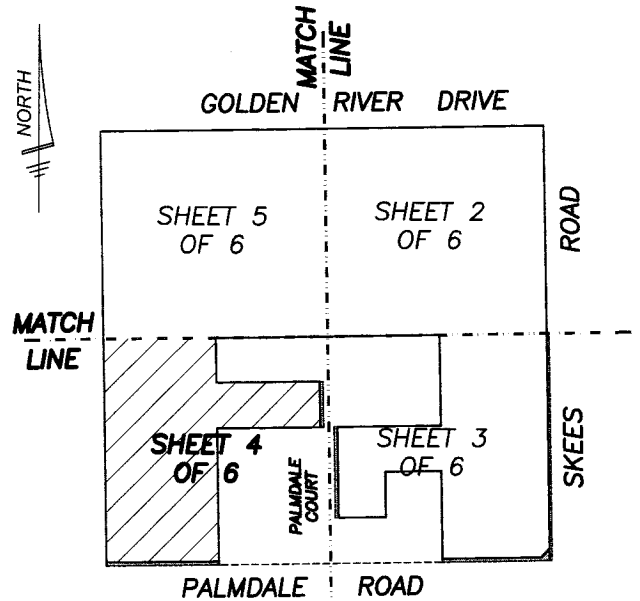
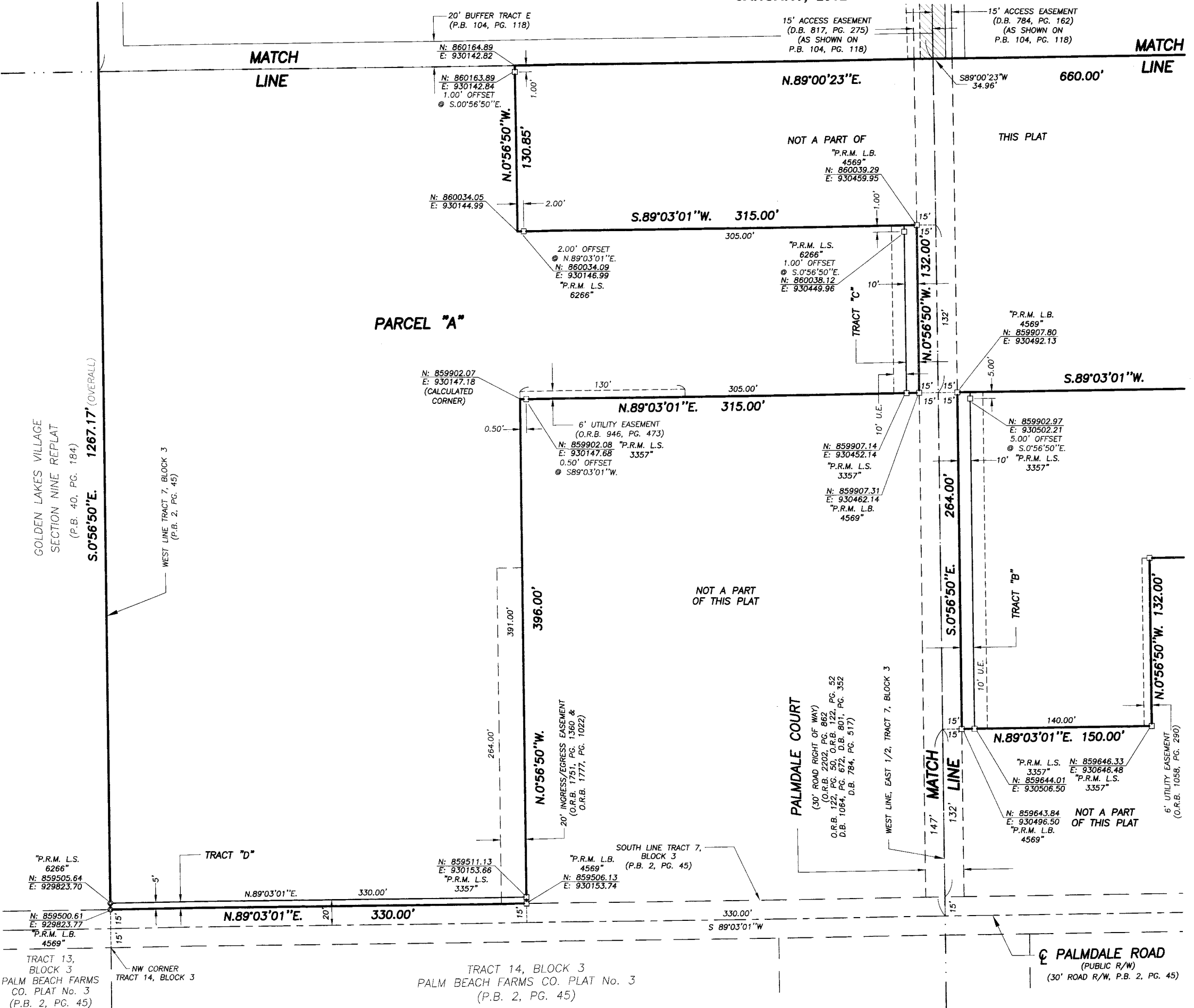

SHEET KEY MAP
(NOT TO SCALE)

- ABBREVIATIONS AND SYMBOLS**
- = SET 4"x4" CONCRETE MONUMENT WITH DISK (AS NOTED ON MAP)
 - = CONCRETE MONUMENT FOUND (AS NOTED ON MAP)
 - ⊙ = SET MAG NAIL & DISK STAMPED (AS NOTED ON MAP)
 - C/L = CENTERLINE
 - R/W = RIGHT OF WAY
 - P.B. = PLAT BOOK
 - PG(S) = PAGES
 - SEC. = SECTION
 - TWP. = TOWNSHIP
 - RGE. = RANGE
 - U.E. = UTILITY EASEMENT
 - D.E. = DRAINAGE EASEMENT
 - D.B. = DEED BOOK
 - A = ARC LENGTH
 - Δ = CENTRAL ANGLE
 - R = RADIUS
 - C.B. = CHORD BEARING
 - O.R.B. = OFFICIAL RECORDS BOOK
 - R.P.B. = ROAD PLAT BOOK
 - L.A.E. = LIMITED ACCESS EASEMENT
 - L.M.E. = LAKE MAINTENANCE EASEMENT
 - L.M.A.E. = LAKE MAINTENANCE ACCESS EASEMENT
 - P.O.B. = POINT OF BEGINNING
 - P.O.C. = POINT OF COMMENCEMENT
 - P.B.C. = PALM BEACH COUNTY
 - N = NORTHING
 - E = EASTING
 - L.B. = LANDSCAPE BUFFER
 - P.B.C.U.E. = PALM BEACH COUNTY UTILITY EASEMENT

PLAT OF HIPPOCRATES PUD/CLF

WALLACE SURVYNG
CORP. LICENSED SURVEYOR # 4889
8553 VILLAGE BOULEVARD, WEST PALM BEACH, FLORIDA 33417 (561) 943-4511

FIELD:	JOB No.: 04-1160.034	F.B.	PG.
OFFICE: R.C.	DATE: SEPT. 2008	DWG. No.:	04-1160-10
C'KD:	REF.: 04-1160.DWG	SHEET 4 OF 6	