

COUNTY OF PALM BEACH)
 STATE OF FLORIDA) SS
 THIS PLAN WAS FILED FOR RECORD AT)
 M. THIS) 2014, AND DULY)
 RECORDED IN PLAT BOOK NO.)
 ON PAGE) THRU)
 SHARON R. BOCK,
 CLERK AND COMPTROLLER
 BY:) D.C.

DOWNTOWN AT THE GARDENS

LYING IN SECTION 6, TOWNSHIP 42 SOUTH, RANGE 43 EAST, CITY OF PALM BEACH GARDENS, PALM BEACH COUNTY, FLORIDA, BEING A REPLAT OF TRACT "A", DOWNTOWN AT THE GARDENS AND LANDMARK AVENUE, AS RECORDED IN PLAT BOOK 101, PAGES 12 THROUGH 15, PUBLIC RECORDS OF PALM BEACH COUNTY, FLORIDA, AND A PORTION OF KYOTO GARDENS DRIVE, AS RECORDED IN OFFICIAL RECORD BOOK 8292, PAGE 1543, PUBLIC RECORDS OF PALM BEACH COUNTY, FLORIDA,

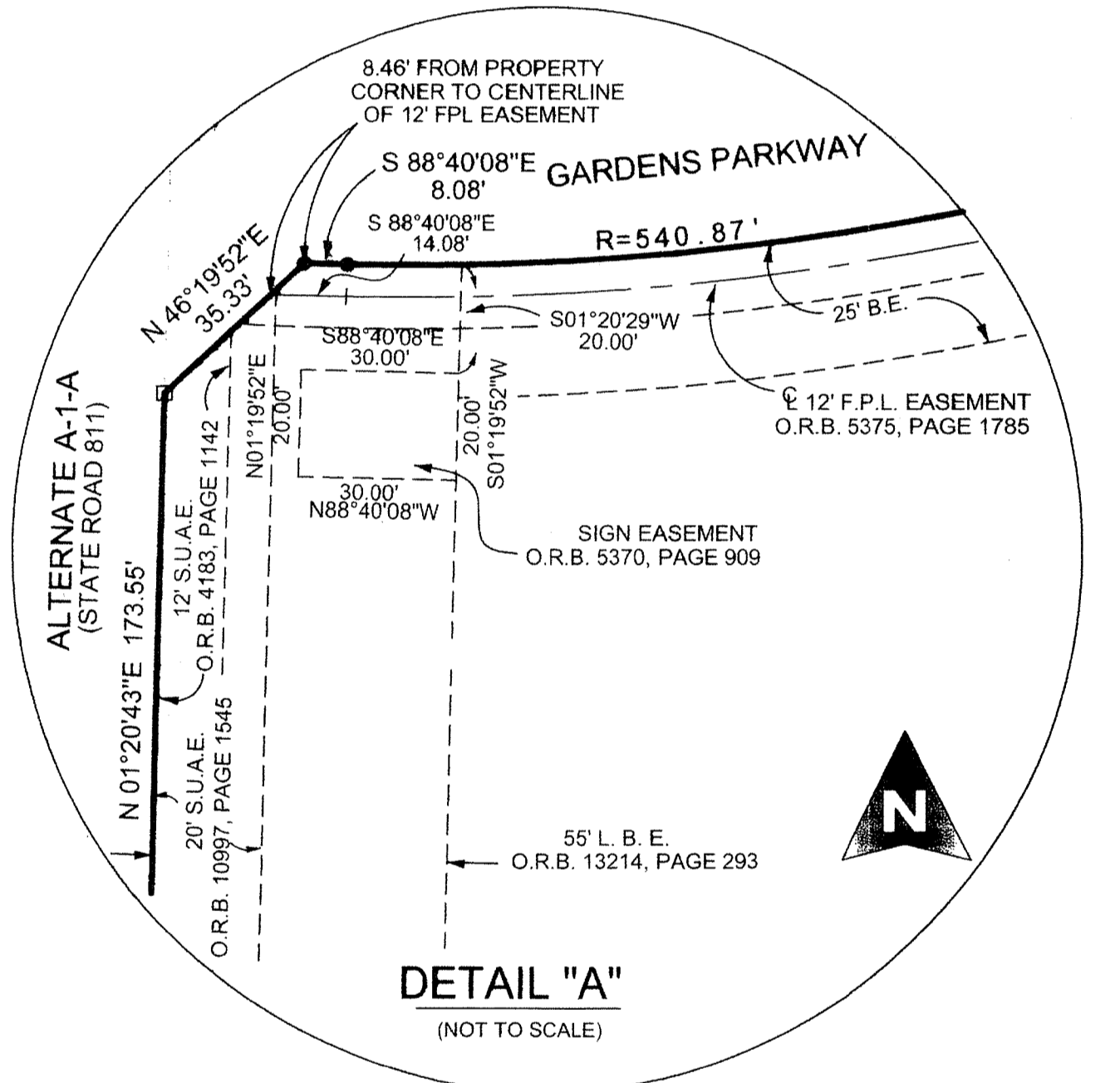
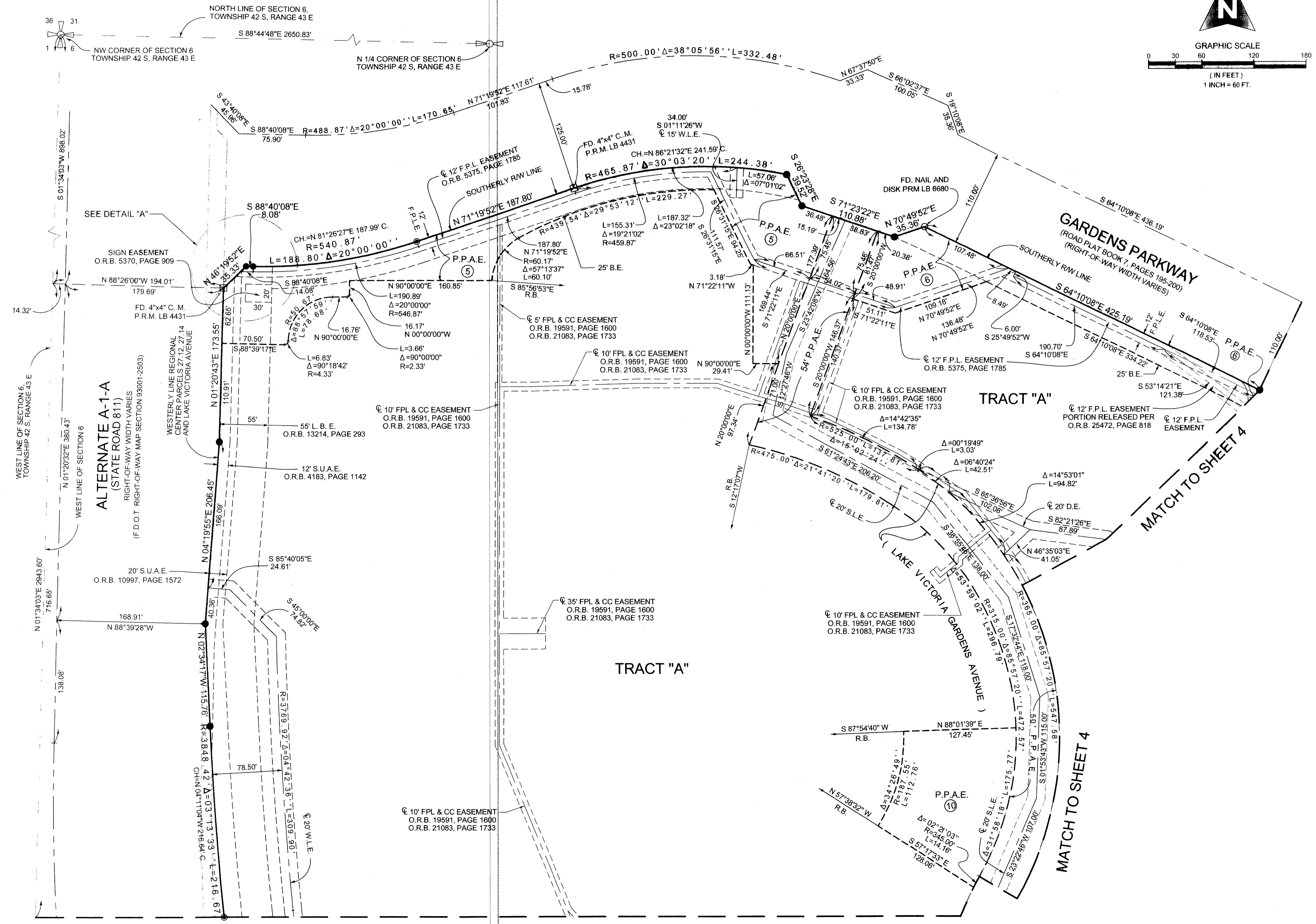
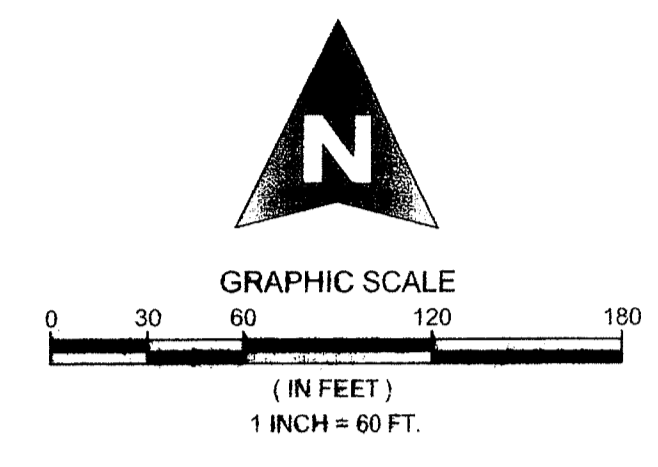
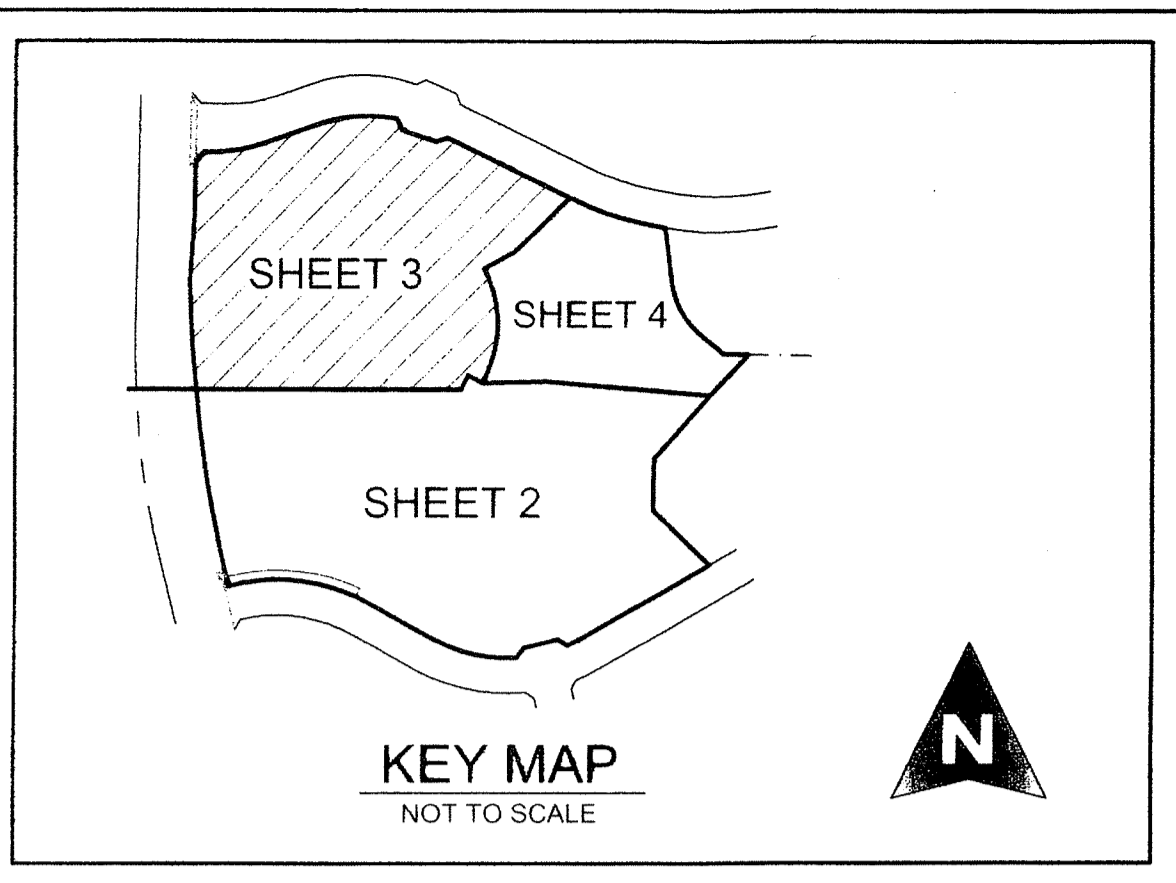

AREA TABULATION (P.P.A.E. 1-6, 7A AND 10)

①	= 11.78	ACRES
②	= 2.32	ACRES
③	= 0.31	ACRES
④	= 0.33	ACRES
⑤	= 0.92	ACRES
⑥	= 0.50	ACRES
⑦	= 0.01	ACRES
⑧	= 0.44	ACRES
TOTAL	= 16.61	ACRES

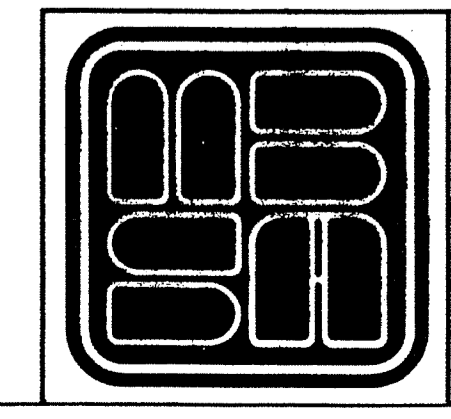

MICHAEL B. SCHORAH & ASSOCIATES, INC.
 1850 FOREST HILL BLVD., SUITE 206
 WEST PALM BEACH, FLORIDA 33406
 EB# 2438 TEL. (561) 968-0080 FAX. (561) 642-9726 LB# 2438

Z:\Downtown at the Gardens (1504)\SURVEY\1504_PLAT.dwg, 7/23/2014 3:34:54 PM, kbsaoull