

# ARDEN P.U.D. POD A WEST AND POD B WEST

BEING A REPLAT OF A PORTION OF TRACT "FD", ARDEN PLAT 1, AS RECORDED IN PLAT BOOK 122, PAGES 32 THROUGH 51, PUBLIC RECORDS OF PALM BEACH COUNTY, FLORIDA, AND LYING IN SECTIONS, 28 AND 33, TOWNSHIP 43 SOUTH, RANGE 40 EAST, PALM BEACH COUNTY, FLORIDA.  
SHEET 3 OF 13

138

COUNTY OF PALM BEACH )  
STATE OF FLORIDA ) SS  
THIS PLAT WAS FILED FOR RECORD AT )  
M. THIS DAY OF )  
2016, AND DULY )  
RECORDED IN PLAT BOOK NO. )  
ON PAGE THRU )  
SHARON R. BOCK,  
CLERK AND COMPTROLLER  
BY: \_\_\_\_\_, D.C.

### COORDINATES NOTE:

STATE PLANE COORDINATES SHOWN ARE GRID  
DATUM = NAD 83, 1990 ADJUSTMENT  
ZONE = FLORIDA EAST  
LINEAR UNITS = US SURVEY FOOT  
COORDINATE SYSTEM 1983 STATE PLANE TRANSVERSE MERCATOR PROJECTION  
ALL DISTANCES ARE GROUND  
PROJECT SCALE FACTOR = 0.99999219  
GROUND DISTANCE X SCALE FACTOR = GRID DISTANCE  
BEARINGS AS SHOWN HEREON ARE GRID DATUM, NAD 83 1990 ADJUSTMENT,  
FLORIDA EAST ZONE.

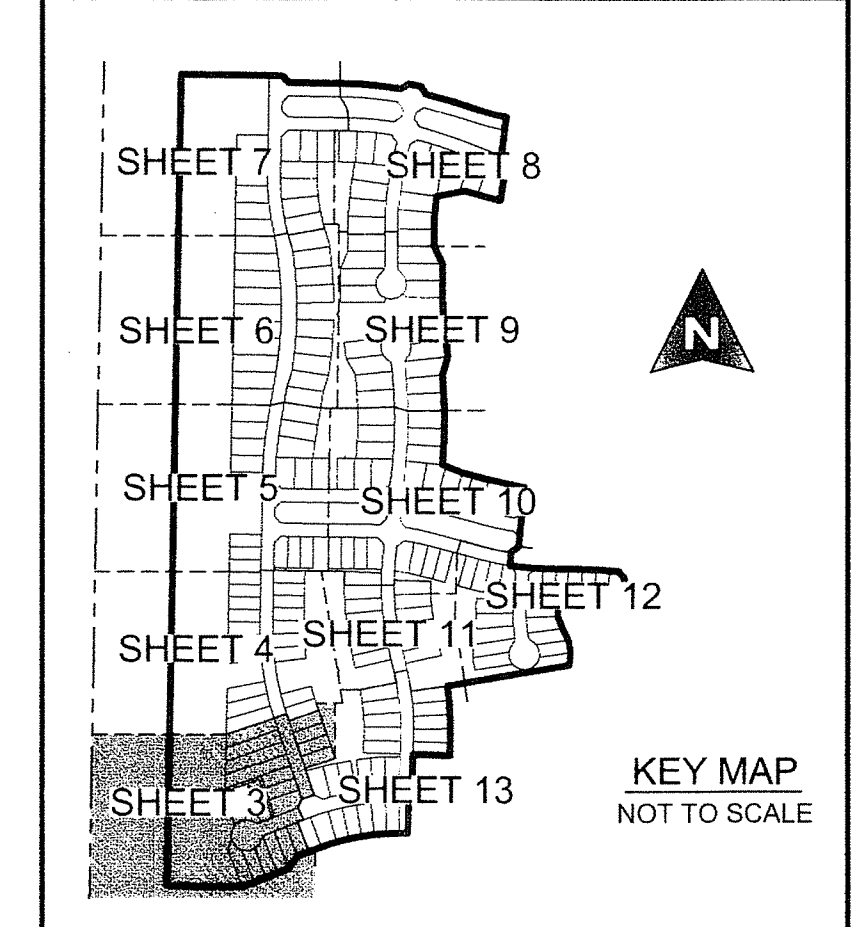
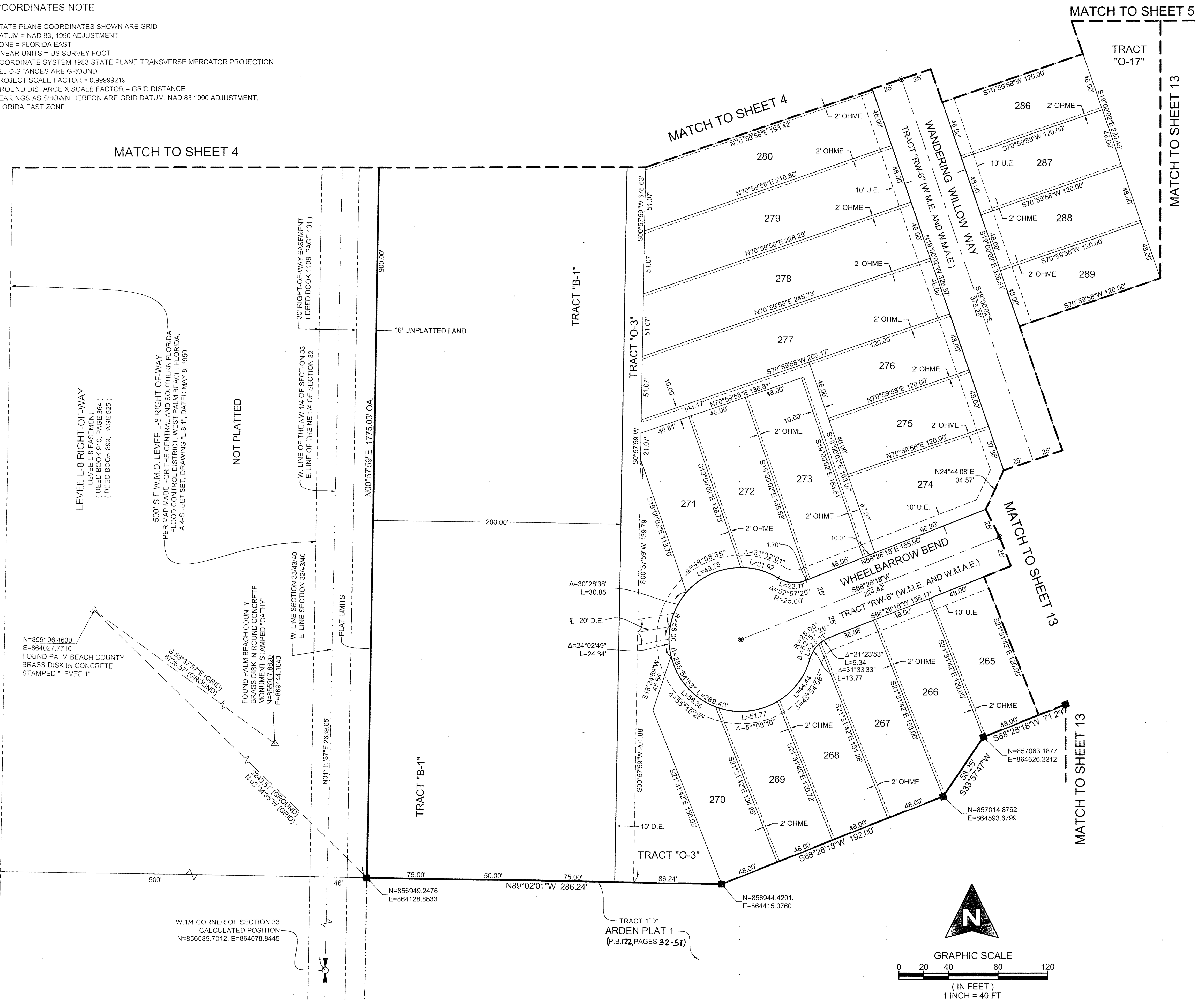

**LEGEND**

- = POINT OF COMMENCEMENT
- = POINT OF BEGINNING
- = PERMANENT CONTROL POINT
- = PERMANENT REFERENCE MONUMENT
- = OFFICIAL RECORD BOOK
- = PLAT BOOK
- = PAGES
- = DEED BOOK
- = PALM BEACH COUNTY
- = RIGHT OF WAY
- = CENTERLINE
- = UTILITY EASEMENT
- = DRAINAGE EASEMENT
- = RADIUS
- = ARC LENGTH
- = CURVE CENTRAL ANGLE
- = DENOTES FOUND PALM BEACH COUNTY DISK IN CONCRETE
- = SET NAIL AND ALUMINUM DISK, STAMPED P.C.P. L.B. 2438
- = SET 4"x4"x24" C.M. WITH ALUMINUM DISK, STAMPED P.R.M. L.B. 2438
- = DENOTES FOUND P.R.M. (AS SHOWN IF ANY)
- = CHORD LENGTH
- = CHORD BEARING
- = LAKE MAINTENANCE ACCESS EASEMENT
- = RADIAL LINE
- = NORTHING, WHEN USED WITH COORDINATES
- = EASTING, WHEN USED WITH COORDINATES
- = LANDSCAPE BUFFER EASEMENT
- = LIMITED ACCESS EASEMENT
- = LIFT STATION EASEMENT
- = FOUND
- = OVERALL
- = CONCRETE MONUMENT
- = FLORIDA POWER AND LIGHT
- = LANDSCAPE EASEMENT
- = PATHWAY EASEMENT
- = PALM BEACH COUNTY UTILITY EASEMENT
- = WATER MANAGEMENT EASEMENT
- = WATER MANAGEMENT ACCESS EASEMENT
- = OVERHANG MAINTENANCE EASEMENT
- = PROFESSIONAL SURVEYOR AND MAPPER
- = NUMBER
- = PLANNED UNIT DEVELOPMENT

SHEET 3 OF 13

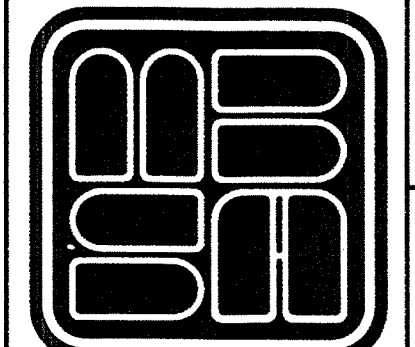
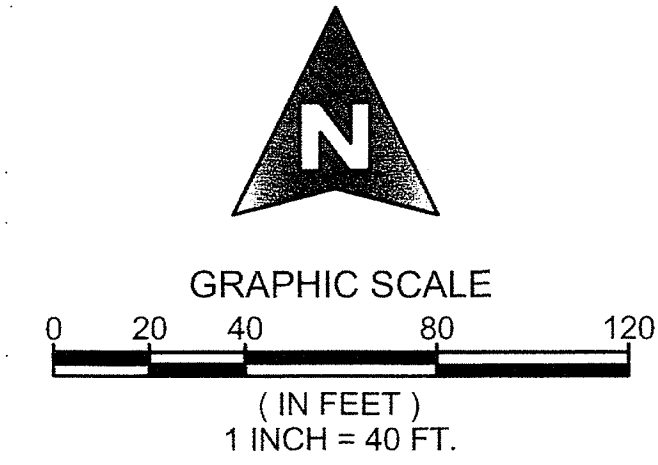

**MICHAEL B. SCHORAH & ASSOCIATES, INC.**  
1850 FOREST HILL BLVD., SUITE 206  
WEST PALM BEACH, FLORIDA 33406  
EB# 2438 TEL. (561) 968-0080 FAX. (561) 642-9726 LB# 2438

ARDEN P.U.D. POD A WEST AND POD B WEST