

MARINA BAY

A REPLAT OF LOTS 8, 9, 10, 11, 12, AND 19, A SUBDIVISION OF BLOCK 126,
 DELRAY, FLORIDA (PLAT BOOK II, PAGE 4, P.B.C.R.)
 SECTION 16, TOWNSHIP 46 SOUTH, RANGE 43 EAST
 CITY OF DELRAY BEACH, PALM BEACH COUNTY, FLORIDA

SHEET 2 OF 2 SHEETS

163

THIS INSTRUMENT PREPARED BY:
 MICHAEL D. ROSE, PSM

SDA SHAH ENGINEERING & ASSOCIATES SURVEYING & PLANNING
 CERTIFICATE OF AUTHORIZATION NO. LB6456
 1885 W. Commercial Blvd., Suite 190 • Ft. Lauderdale, FL 33309
 PH: 954-776-7604 • FAX: 954-776-7608
 JULY 2000

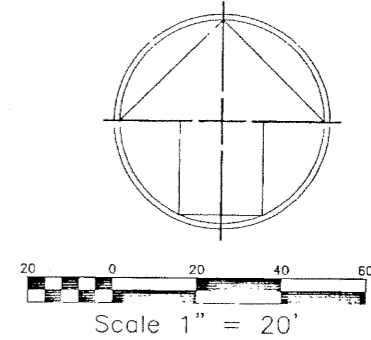

STATE OF FLORIDA
 COUNTY OF PALM BEACH
 This Plat was filed for record at _____ M., this _____ day of _____, 2000, and duly recorded in Plat Book No. _____ on Pages _____ and _____
 DOROTHY H. WILKEN, CLERK
 BY: _____ DC

SURVEY NOTES:

- BEARINGS SHOWN HEREON ARE RELATIVE TO THE EAST LINE OF BLOCK 126, SAID LINE BEARS: NORTH (ASSUMED).
- NOTICE: THIS PLAT, AS RECORDED IN ITS GRAPHIC FORM, IS THE OFFICIAL DEPICTION OF THE SUBDIVIDED LANDS DESCRIBED HEREIN AND WILL IN NO CIRCUMSTANCES BE SUPPLANTED IN AUTHORITY BY ANY OTHER GRAPHIC OR DIGITAL FORM OF THE PLAT. THERE MAY BE ADDITIONAL RESTRICTIONS THAT ARE NOT RECORDED ON THIS PLAT THAT MAY BE FOUND IN THE PUBLIC RECORDS OF PALM BEACH COUNTY.
- THERE SHALL BE NO TREES OR SHRUBS PLACED ON UTILITY EASEMENTS WHICH ARE PROVIDED FOR WATER AND SEWER USE OR UPON DRAINAGE EASEMENTS. LANDSCAPING ON OTHER UTILITY EASEMENTS SHALL BE ALLOWED ONLY AFTER CONSENT OF ALL THE UTILITY COMPANIES OCCUPYING SAME.
- - DENOTES PERMANENT REFERENCE MONUMENT (PRM) NO. LB6456
 - P.B. - DENOTES PLAT BOOK
 - ORB - DENOTES OFFICIAL RECORDS BOOK
 - PG - DENOTES PAGE
 - C - DENOTES CENTERLINE
 - U.E. - DENOTES UTILITY EASEMENT
 - G.U. - DENOTES GENERAL UTILITY EASEMENT
 - R - DENOTES RADIUS
 - D - DENOTES CENTRAL ANGLE
 - L - DENOTES ARC LENGTH
- THE CITY OF DELRAY BEACH SHALL HAVE THE RIGHT OF ACCESS FOR EMERGENCY AND MAINTENANCE PURPOSES WITHIN THE LIMITS OF THIS SUBDIVISION

