

2C-1

EXHIBIT F

**Palm Beach County
Biotechnology Research Park**

Design Standards



**Submitted June 2, 2004
Rezoning/Requested Use Approval
Final September 23, 2004**

Prepared by:
Kilday & Associates
1551 Forum Place, Suite 100A
West Palm Beach, FL 33401
(561) 689-5522 (Phone)
(561) 689-2592 (Fax)

Table of Contents

INTRODUCTION	2
CHAPTER 1 MASTER PLAN OVERVIEW	5
CHAPTER 2 GENERAL STANDARDS.....	6
Section 1 Block Style.....	6
Section 1 Block Style.....	6
Section 2 Campus Style	10
CHAPTER 3 PODS.....	13
Section 1 Industrial.....	13
Section 2 Commercial	14
Section 3 Residential.....	17
Section 4 Recreation/Civic	19
CHAPTER 4 OPEN SPACE	21
Section 1 The Pedestrian Mall	21
Section 2 The Promenade.....	23
Section 3 The BTP Natural Area	25
CHAPTER 5 TRANSPORTATION.....	26
Section 1 Streets	26
Section 2 Pedestrian Systems.....	33
Section 3 Alternative Vehicular Systems.....	36
CHAPTER 6 ARCHITECTURE.....	40
Section 1 Purpose and Intent	40
Section 2 Applicability	40
Section 3 Design Elements	40
Section 4 Unique Structures.....	42
Section 5 Green Building.....	43
Section 6 Additional Conservation Strategies	43
Section 7 Site Furnishings.....	44
CHAPTER 7 LANDSCAPE	46
Section 1 Purpose and Intent	46
Section 2 General.....	46
CHAPTER 8 PARKING.....	48
Section 1 Purpose and Intent	48
Section 2 General.....	48
CHAPTER 9 SIGNAGE AND SITE LIGHTING	50
Section 1 Signage	50
Section 2 Site Lighting.....	51
CHAPTER 10 IMPLEMENTATION.....	52



INTRODUCTION

The Palm Beach County Biotechnology Research Park (Research Park) is a Planned Industrial Park Development (PIPD) situated on approximately 1,919.23 acres of property in the north central portion of Palm Beach County. This project will primarily consist of land uses related to science & technology, biotechnology, biomedical, and other related research & development industries, and manufacturing. Additionally, there will be associated support and complementary land uses including: a satellite university campus; institutional uses; a residential component with a variety of housing types primarily for workforce housing; neighborhood and community commercial centers with restaurants, convenience retail, and personal service uses; and community facilities, including parks, recreation, government services, and opportunities for secondary and post-secondary education.

Intent

It is the intent of Palm Beach County to develop a project that is a sustainable and economically viable live/work/play environment by creating a Master Plan that clusters the uses to promote intellectual exchange between the researchers, scientists, and other members of the workforce; provides for a range of workforce housing to help maximize internal trip capture, minimize traffic impacts on surrounding roadways, and provide obtainable housing for administrative and support staff; provides convenient retail, restaurant, and other shopping opportunities for the workforce and residents; and promotes an integrated development that encourages transportation alternatives to the automobile by incorporating a connected pathway, bikeway, and multi-use trail system throughout the project.

The impact of the project on the surrounding area, including the conservation lands to the north and west, and the low density residential to the south, has been strongly considered as part of the programming and preliminary design of the master plan. The existence of such valuable resources helps to encourage the theory of sustainable design.

These Design Standards will set forth the governing principles for the development and shall be considered to be a supplement to the Unified Land Development Code (ULDC), as approved under Ordinance 2003-67, and the governing Regulating Plan, as required by ULDC Article 3.E.1.D(3); and all Regional and Local Conditions of Approval. The Design Standards shall not supersede any of the above.

Goals

Broad principles guide sustainable land use planning and development. The project's design furthers these goals, which are to conserve and protect natural and man-made resources; prevent urban sprawl through establishment of urban intensity areas; provide for sufficient open space; create quality livable



communities by balancing, distributing and integrating the relationship among land uses to meet the needs of a diverse population and their associated life-style choices; manage the development of land and service delivery, so that its use is appropriate, orderly, timely and cost effective; and promote sustainable economic development initiatives with the purpose of diversifying the economic base and enhancing the quality of life and well-being of current and future generations.

Scientific Community Overlay

The project is designated with a Scientific Community Overlay land use designation that will provide for an array of services designed to allow for functional interaction with the predominate science and technology based uses. The Overlay implements a unique opportunity for Palm Beach County to incorporate a regional economic development initiative providing a functional mix of uses. Palm Beach County shall provide primary uses for research, development, and manufacturing activities contained within a sustainable community.

The Overlay requires an integrated mix of uses that provides for secondary uses and promotes economic development while preserving and enhancing natural resources. It is through the incorporation of other support uses, such as residential, commercial, institutional, and recreation, that a balanced and sustainable community will be formed.

Planned Industrial Park Development District

The project will also be designated as a Planned Industrial Park Development District (PIPD). A PIPD is an economic activity center primarily designed to accommodate and promote a mix of uses, both primary and secondary, that serve the projected workforce and residential population. Commercial, employment, institutional, and residential uses are permitted and a balanced mix of land uses must be provided.

Master Plan

A Development of Regional Impact was the first step in the creation of the Design Standards and Master Plan. The DRI included a more generalized set of Design Guidelines that helped to identify the overall intent of the project's design. Map H of the DRI application divided the property into several "districts" to identify the distribution of uses throughout the project. The Master Plan now has been further separated into "Pods." The Pods help to further define the intent of each district and provide more detail with regards to use distribution and intensity.

Design Standards

These Design Standards have been created to serve as a supplement to the requirements identified in the Palm Beach County Unified Land Development Code (ULDC). These Design Standards will act in conjunction with the Regulating Plan and shall govern the development of the Research Park, along

with the ULDC and all Regional and Local Conditions of Approval. Within these Design Standards, along with the Master Plan, the development Pods and permitted uses will be established. Design theory and criteria, as well as general property development regulations, will be set forth for implementation. Successful implementation of these Design Standards will be imperative to the creation of a world class research park.



CHAPTER 1 MASTER PLAN OVERVIEW

In order to create a "World-Class" Research Park, one must ensure that the proper uses and design styles are organized appropriately. Therefore, the PIPD has been organized into "Pods," which identify the various uses that may be developed and defines their relationships to one another. The Master Plan has been broken down into the following Land Use Pods:

- Light Industrial
- Commercial
- Recreation/Civic
- Residential

The Pod locations were determined after careful study and research with regards to use, site constraints, functional relationships, and overall design. The Pod designations are identified on the PIPD Master Plan.

Design Standards have been established for each Pod type to further enhance the intended character and use within them. Each Pod is permitted a variety of uses (as identified in the PIPD regulations of the ULDC and on the Master Plan) which are meant to complement one another to create a cohesive development. The design style of each Pod is identified within these Design Standards in order to create a functional and enjoyable environment. Pursuant to the Subdivision Ordinance set forth by the ULDC, each Pod may be further subdivided and/or development may be phased.

Beyond the development Pods, the Master Plan also identifies those areas of the Research Park which are intended for public use, including: a Pedestrian Mall, an interconnected greenway/pedway/trail system, BTP Natural Areas, and retention/lake areas. Detailed Design Standards have been created for these areas as well and are also included in this document.

Due to project development timing, the initial phase of development, the first three structures for *The Scripps Research Institute (TSRI)* in Pod N, shall be exempt from these Design Standards, except as set forth in Chapter 3 of this document. However, this Phase shall be subject to the ULDC and any applicable Regional or Local Conditions of Approval.

CHAPTER 2 GENERAL STANDARDS

Section 1 Applicability

The standards and requirements set forth in this Chapter shall be applicable only to non-residential development.

Section 2 Block Style

A. Purpose and Intent

The purpose and intent of Block Style are to:

1. Establish a consistent style of development within specific Pods in the Research Park.
2. Provide an identifiable central core for the Research Park.
3. Create an urban, pedestrian-oriented environment with a mix of uses.

B. Pod Designations

1. Those pods which are designated as "Block" on the Master Plan shall be developed in accordance with the Block Style development standards.
2. All other pods within the Research Park, not designated "Block" may be developed in accordance with the Block Style or Campus Style development standards.
3. Block Style development located within Pods not previously designated as Block Style, shall only occur either:
 - a) Adjacent to another Block Style pod; or
 - b) At the intersection of two arterial or collector streets with a minimum frontage of 200 feet along each of the two streets.

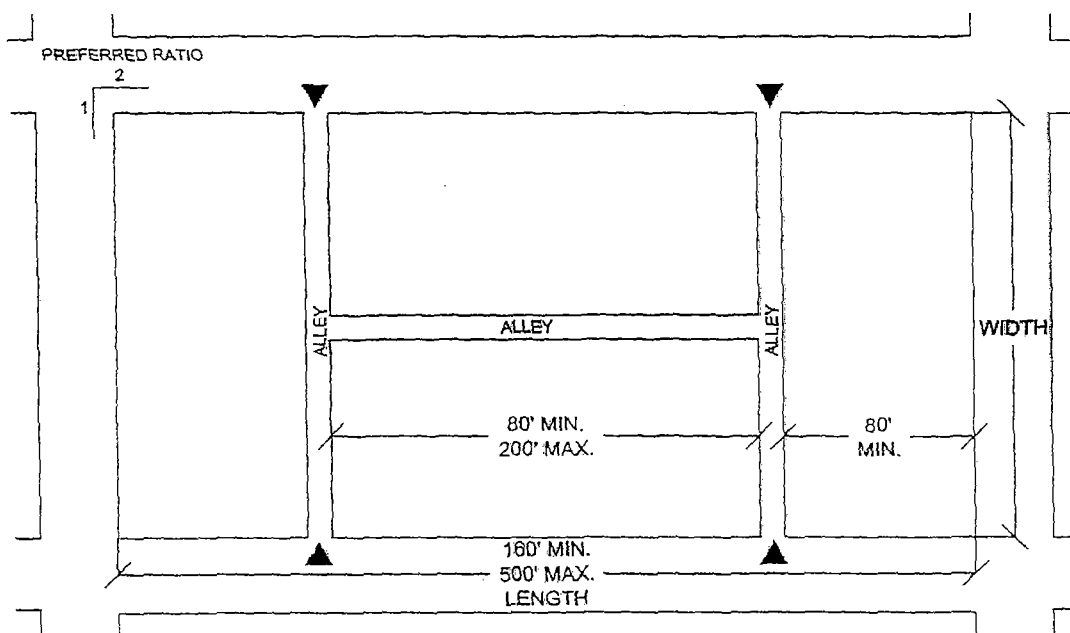
C. Development Standards

1. Block Structure (Fig. 2.1)
 - a) Length: Minimum 160 feet; Maximum 500 feet
 - b) Width: Preferred ratio of block length to width shall be 2:1.
2. Street Designations and Configurations
 - a) Mainstreet
 - (1) A tertiary street located within a Block Style development.
 - (2) A minimum of two, two-way streets within each Block Style pod shall form an intersection and be designated as Mainstreets.
 - (3) All Mainstreets shall cross through the entire length and/or width of a Block Style pod.
 - b) Minor Streets
 - (1) A tertiary street located within a Block Style development, not designated as a Mainstreet.

c) Alleys

- (1) Alleys shall be provided in accordance with ULDC regulations for Traditional Development District Alley Design Standards. (Figure 2.1)
- (2) The maximum number of alley curb cuts per block shall be five (maximum two per side).
- (3) The minimum spacing between alley curb cuts shall be 80 feet.
- (4) The maximum spacing between alley curb cuts shall be 200 feet.
- (5) The minimum spacing between alley curb cuts and an intersection shall be 80 feet.
- (6) All service areas shall be accessed from alleys and shall not be visible from Mainstreets, Minor Streets, plazas, or squares.
- (7) Alley access is not permitted from a Primary or Secondary Street, as defined in Chapter 5 of this document.
- (8) Alley access shall not be permitted from any street which is adjacent to the Pedestrian Mall.

Figure 2.1 – Block Structure



3. Each building or structure, excluding Unique Structures, shall be a minimum of 2 stories and a maximum of 3 stories, not to exceed 65 feet in height.
4. The primary entrance of every building shall face a public street.
5. Frontage. (Figure 2.2)
 - a) Each building or structure shall be located within 15 feet of the required sidewalk or build-to line, which is typically the right of way line. (Figure 2.3)



- b) All building frontages shall be designated on the site plan and shall conform to the following requirements:
- (1) Frontage shall be designated along a minimum of 80% of the length of a block along a Primary Street.
 - (2) Frontage shall be designated along a minimum of 70% of the length of a block along a Secondary Street.
 - (3) Frontage shall be designated along a minimum of 60% of the length of a block along a Mainstreet.
 - (4) Frontage shall be designated along a minimum of 40% of the length of a block along all Minor Streets.
 - (5) Frontage shall be continuous, except as follows:
 - (a) A central plaza or square.
 - (b) Separation between buildings is allowed provided it is located a minimum of 80 feet from the end of a block for any of the following:
 - (i) Pedestrian access
 - (ii) Alleys
 - (iii) Plazas or squares.

Figure 2.2 – Frontages

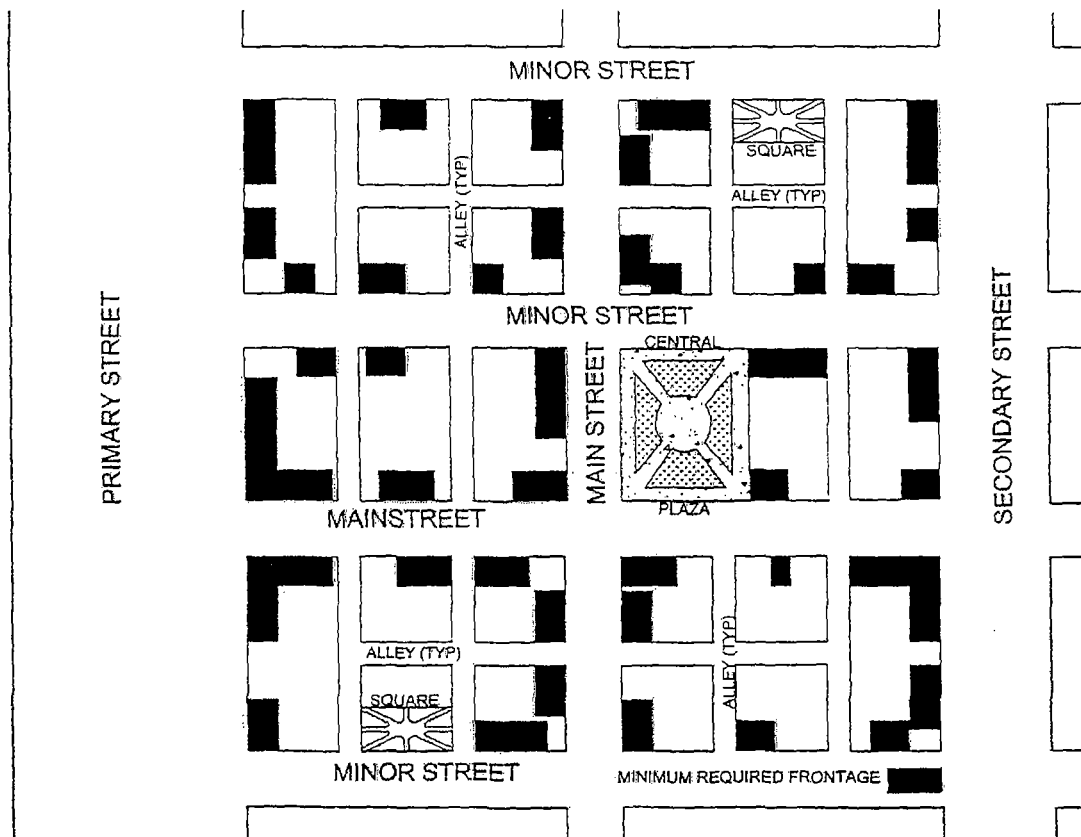
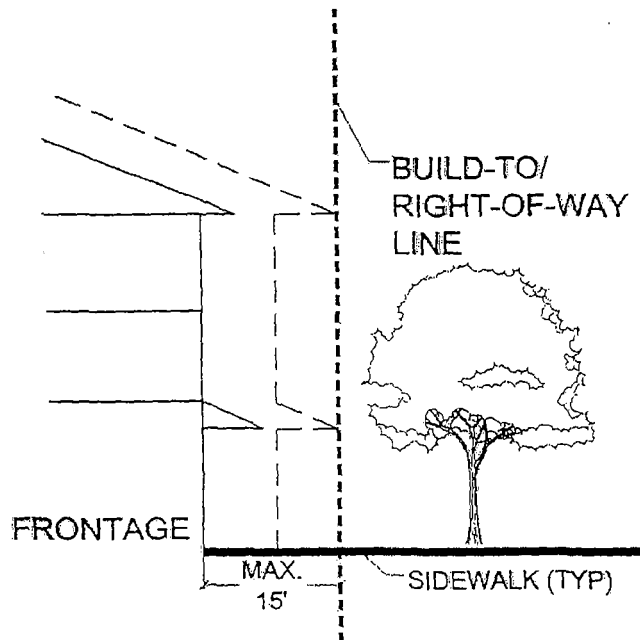


Figure 2.3 – Build-To Lines



D. Plazas and Squares (Figure 2.4)

Public plazas and Squares are required to provide focal points and rest areas for pedestrians, subject to the following standards:

1. Development Patterns

- a) If two or fewer contiguous blocks are developed simultaneously, then a minimum of one public plaza or square shall be provided in accordance with the standards set forth below.
- b) If more than two contiguous blocks are developed simultaneously, then a minimum of 20,000 square feet or five percent of the gross land area of the subject blocks, whichever is greater, shall be designated for use as public plazas or squares and shall include a minimum of one Central Plaza.

2. Design Standards

a) Minimum Size

- (1) Central Plaza: 20,000 square feet
- (2) Other Plazas and Squares: 10,000 square feet

b) Required Location.

- (1) The Central Plaza shall be bounded by streets on at least three sides and shall front on a Mainstreet.
- (2) Other Plazas and Squares shall be bounded by a street on at least one side.

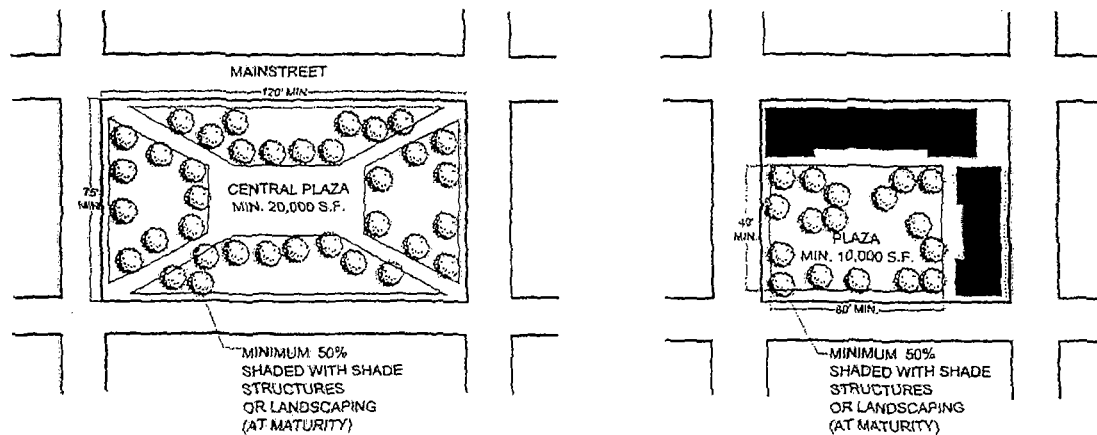
c) Required Dimensions

(1) Minimum Length

- (a) Central Plaza: 120 feet
- (b) Other Plazas and Squares: 50 feet

- (2) Minimum Width
 - (a) Central Plaza: 75 feet
 - (b) Other Plazas and Squares: 40 feet
- d) Required Landscaping and Pedestrian Amenities
 - (1) A minimum of 50 percent of the total area of each plaza and square shall be shaded by landscaping or shade structures.
 - (2) A minimum of 40 percent of the total area of each plaza and square shall be pervious area.
 - (3) Each plaza and square shall provide a minimum of one linear foot of seating for each 200 square feet of overall area.
- 3. All plazas and squares shall be perpetually maintained by the property owner or dedicated to the Property Owner's Association (POA).

Figure 2.4 – Required Plazas and Squares



Section 3 Campus Style

A. Purpose and Intent

The purpose and intent of Campus Style is to:

1. Provide a flexible development option which would allow parcels to be combined or further subdivided.
2. Provide development opportunities for uses that need added security or ample land area to be successful.

B. Pod Designations

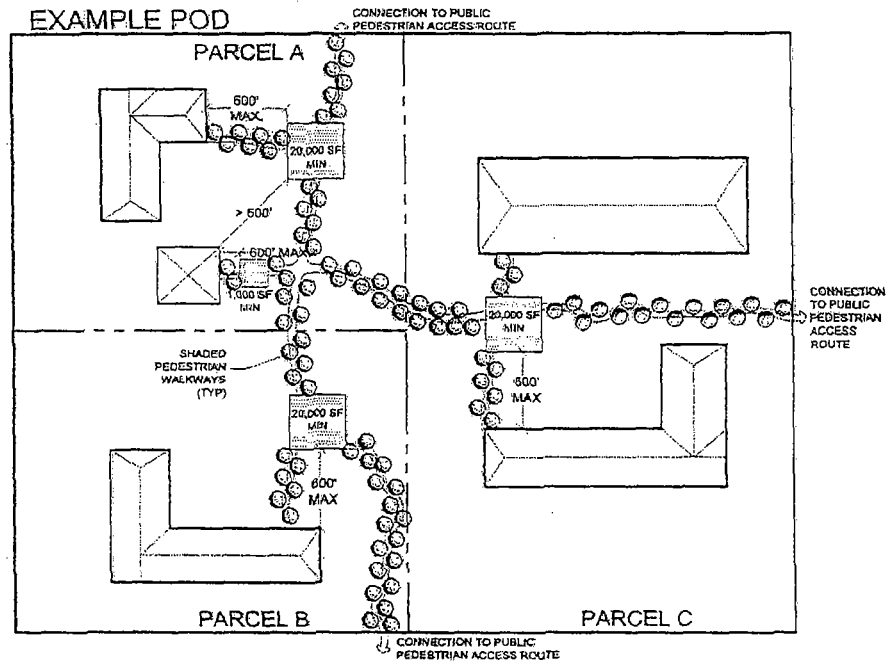
1. Those Pods which are not designated as "Block" on the Master Plan shall be developed in accordance with the Campus Style development standards.
 - a) Conversion to Block Style is permitted as outlined in Chapter 2 Section 2.B.3.

C. Development Standards

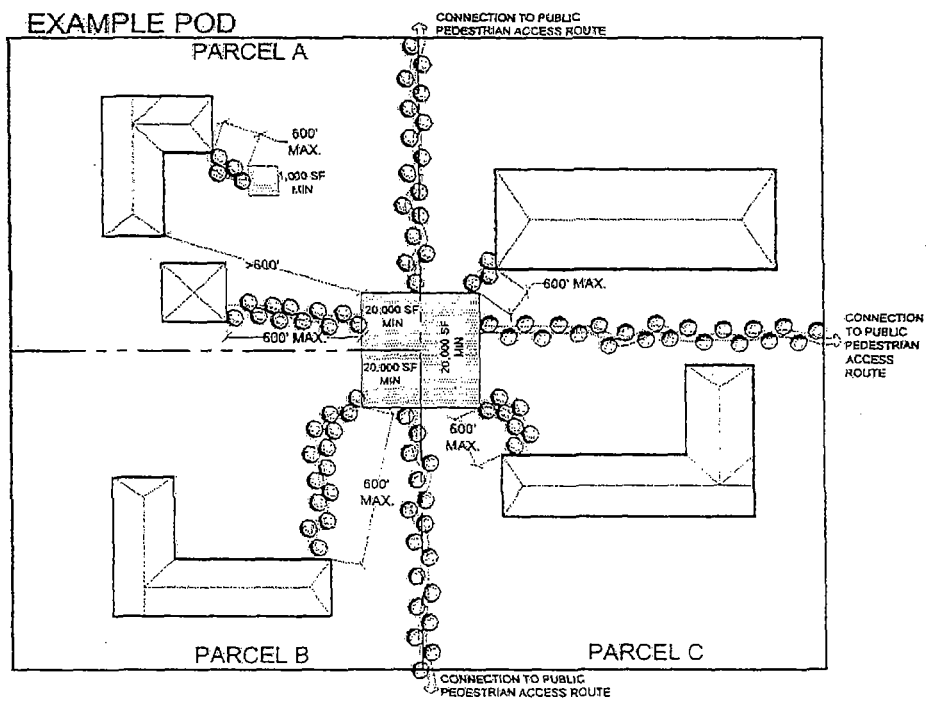
1. Each Campus Style pod shall provide a minimum of one centrally located open space, park, plaza, or green which shall:

- a) Be open for the use of the employees.
 - b) Be a minimum of 20,000 contiguous square feet with a minimum width of 100 linear feet.
 - c) Have a minimum of 50 percent pervious area.
 - d) Provide shade for a minimum of 50 percent of the total area through the use of canopy trees (at maturity) and/or shade structures.
 - e) Provide a minimum 8' wide shaded pedestrian connections to adjacent structures and public pedestrian access routes and any additional open space areas located within the pod or parcel. Pedestrian paths shall not be included in minimum size requirements for open space areas.
 - f) Be constructed prior to the issuance of the first Certificate of Occupancy (CO) for the Pod or Parcel.
 - g) Be located a maximum of 600 feet from each structure.
 - (1) If any structure within a Campus Style pod cannot be located within 600 feet of the central open space area then additional open space areas shall be provided within 600 feet of each structure and shall:
 - (a) Be a minimum of 1,000 contiguous square feet with a minimum width of 30 feet.
 - (b) Be constructed prior to the issuance of the first CO for any structure that it is intended to serve.
 - (c) Have a minimum of 50 percent pervious area.
 - (d) Provide shade for a minimum of 50 percent of the total area through the use of canopy trees (at maturity) and/or shade structures.
 - h) All open space, parks, plazas, or greens shall be perpetually maintained by the property owner or dedicated to the Property Owners Association.
2. When a pod is subdivided, then each parcel shall provide the required 20,000 square feet and be designed consistent with the standards listed above.
- a) Each required open space, park, plaza, or green provided within each Pod shall be connected by a shaded pedestrian path. (See Figure 2.5.)
3. Open space, park, plaza, or greens will not be required for utility pods.

Figure 2.5 – Campus Style Open Space



Option A



Option B

CHAPTER 3 PODS

Section 1 Industrial

A. Light Industrial (Excluding Pod N)

1. Purpose and Intent

The purpose and intent of the Light Industrial Pods are to:

- a. Provide economic development and employment opportunities within the Palm Beach County Biotechnology Research Park and the surrounding area.
- b. Serve as the economic core for the Research Park.

2. Uses Allowed

- a. Permitted Uses. Shall correspond to those Use Types permitted in the Light Industrial Pod of a PIPD as set forth by the ULDC.
- b. Requested Uses. Shall be consistent with those identified on the BCC approved Master Plan. Any additional Requested Uses shall be subject to BCC approval.

3. Development Standards

- a. Shall comply with the PIPD standards and requirements in the ULDC for Light Industrial development.
- b. Block Style
Those pods designated as "Block" on the Master Plan shall:
 - (1) Be designed utilizing the Block Style regulations as set forth in Chapter 2 Section 2 of this document.
 - (2) Utilize up to a maximum of 26,000 square feet per acre with a maximum FAR of 0.60.
- c. Campus Style
Those Pods not designated "Block" on the Master Plan shall:
 - (1) Be developed utilizing the Campus Style regulations set forth in Chapter 2 Section 3 of this document.
 - (2) Utilize up to a maximum of 11,000 square feet per acre and a maximum FAR of 0.25.
 - (a) The maximum square footage may be exceeded provided that the Pod is designated as Block Style on the Master Plan and developed utilizing the Block Style regulations set forth in Chapter 2 of this document and based upon Development Review Officer (DRO) approval.
- d. Each parcel or pod shall provide shaded pedestrian connections to the Pedway system to and from each public open space, park, plaza, green, or recreational area.



B. Pod N

1. Purpose and Intent

The purpose and intent of Pod N is to:

- a. Provide a premier location at the south end of the Pedestrian Mall.

2. Uses Allowed

- a. Permitted Uses. Shall correspond to those Use Types permitted in the Light Industrial pod of a PIPD as identified in Table 3.E.1.B-10 PDD Use Matrix.
- b. Requested Uses. Shall be consistent with those identified on the BCC approved Master Plan. Any additional Requested Uses shall be subject to BCC approval.

3. Development Standards

- a. Shall comply with the PIPD standards and requirements in the ULDC for Light Industrial development.
- b. Shall provide a structure at the south terminus of the Pedestrian Mall highly visible from both the Pedestrian Mall and PGA Boulevard.
- c. Shall utilize up to a maximum FAR of 0.45.
- d. Provide shaded pedestrian connections to the Pedway system or other public pedestrian access route to and from each public open space, park, plaza, green, or recreational area.

Section 2 Commercial

A. Commercial Mixed-Use (Town Center) - Pod O

1. Purpose and Intent

The purpose and intent of the Town Center Pod is to:

- a. Encourage mixed-use, compact development that is pedestrian in scale.
- b. Co-locate commercial, transportation, office, laboratory research, educational, and residential uses for the daily needs of the residents and workforce of the Research Park.
- c. Provide for attainable housing opportunities.
- d. Encourage walking, bicycling, and other modes of non-vehicular transportation to reduce the need for local automobile trips.
- e. Provide a safe and efficient circulation system for pedestrians, non-motorized or low-speed vehicles, and automobiles and emphasize connectivity within and to adjacent uses.

2. Uses Allowed

- a. Permitted Uses. Shall correspond to those Use Types permitted in the Commercial Pod of a PIPD as identified in Table 3.E.1.B-10 PDD Use Matrix.
- b. Requested Uses. Shall be consistent with those identified on the BCC approved Master Plan. Any additional Requested Uses shall be subject to BCC approval.
- c. Transportation Facility (Intermodal Center)



- d. Residential. Multi-family; Live/Work Space
 - (1) Live/work space shall not be included in the overall residential density.

3. Development Standards

- a. Shall comply with the MXPB Setback requirements in Article 3 Section 4.d.1 or TMD standards in the ULDC.
- b. Shall be subject to the Block Style regulations, as set forth in Chapter 2 Section 2, and as identified on the BCC Approved Master Plan.
- c. College and University Development may deviate from the Block Style regulations and comply with Chapter 2 Section 3, Campus Style regulations.
- d. No single tenant below 25,000 square feet shall occupy more than 120 linear feet of Primary frontage. No single tenant 25,000 square feet or over shall occupy more than 200 linear feet of Primary frontage. All tenant spaces shall have a minimum depth of 40 feet, measured from the storefront.
- e. No single tenant shall occupy more than 100,000 square feet without approval from the BCC.
- f. The ground floor of any structure located with frontage along a Mainstreet shall be for office or retail uses only.
- g. Each parcel or pod shall provide shaded pedestrian connections to the Pedway system to and from each public open space, park, plaza, green, or recreational area.

B. Commercial (Neighborhood Commercial) – Pod F

1. Purpose and Intent

The purpose and intent of the Neighborhood Commercial Pod is to:

- a. Establish a specific neighborhood identity and focus with a pedestrian-oriented design.
- b. Provide a range of neighborhood commercial and retail uses in close proximity to one another within or near the neighborhoods.
- c. Provide efficient non-vehicular transportation to encourage the use of non-motorized vehicles and pedestrian activity.

2. Uses Allowed

- a. Permitted Uses. Shall correspond to those Use Types permitted in the Commercial Pod of a PIPD as identified in Table 3.E.1.B-10 PDD Use Matrix.
- b. Requested Uses. Shall be consistent with those identified on the BCC approved Master Plan. Any additional Requested Uses shall be subject to BCC approval.

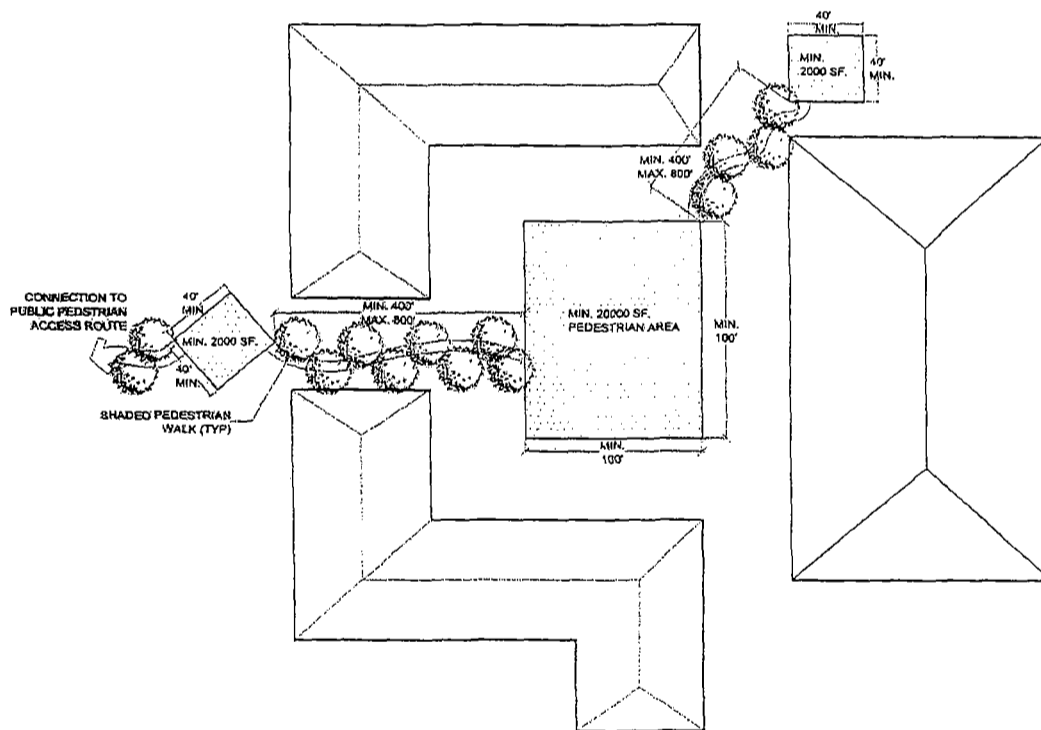
3. Development Standards

- a. May comply with either the Block Style or Campus Style regulations.
- b. Shall provide a minimum of one centrally-located pedestrian-oriented area in the form of a park or plaza to be a minimum size of 20,000 contiguous square feet with a minimum width of 100 linear feet.



- c. Shall provide a minimum of two public seating and gathering areas, in addition to the centrally-located pedestrian-oriented area. (See Figure 3.1)
 - (1) These areas may be in the form of plazas, public outdoor dining areas, fountains, public art displays, clock towers, or any other suitable amenity as determined by the DRO and/or the POA.
 - (2) Such areas shall be a minimum size of 2,000 contiguous square feet with a minimum width of 40 feet.
 - (3) Required public areas shall be located a minimum of 400 feet and a maximum of 800 feet apart, measured between closest exterior edges.
 - (4) All public areas shall be connected by shaded pedestrian paths.
- d. Each parcel or pod shall provide shaded pedestrian connections to the Pedway system to and from each public open space, park, plaza, green, or recreational area.

Figure 3.1 - Pedestrian-Oriented Areas



C. Commercial – Institutional/Education

1. Purpose and Intent

The purpose and intent of the Institutional/Education Pods are to:

- a. Provide educational opportunities for the surrounding residential and workforce uses.

2. Uses Allowed

- a. Permitted Uses. Shall be consistent with those identified on the BCC approved Master Plan.
- b. Requested Uses. Shall be consistent with those identified on the BCC approved Master Plan. Any additional Requested Uses shall be subject to BCC approval.

3. Development Standards

- a. Shall comply with either the Block Style or Campus Style regulations.
- b. All educational structures shall be located outside of the limits of the North County Airport Prohibited Land Use Area 5-Mile Runway Buffer Zone as indicated on the BCC-Approved Master Plan.
- c. Each parcel or pod shall provide shaded pedestrian connections to the Pedway system to and from each public open space, park, plaza, green, or recreational area.

Section 3 Residential

A. Purpose and Intent

The purpose and intent of a Residential Pods are to:

1. Provide a variety of housing types.
2. Provide residential opportunities in close proximity to workplaces, business, retail, shopping, personal services, recreation, and educational facilities.
3. Provide efficient non-vehicular transportation amenities to encourage the use of non-motorized vehicles and pedestrian activity.

B. Uses Allowed

1. Permitted Uses. Shall correspond to those Use Types permitted in the Residential pod of a PUD as identified in Table 3.E.1.B-10 PDD Use Matrix.
2. Requested Uses. Any Requested Uses shall be subject to BCC approval.

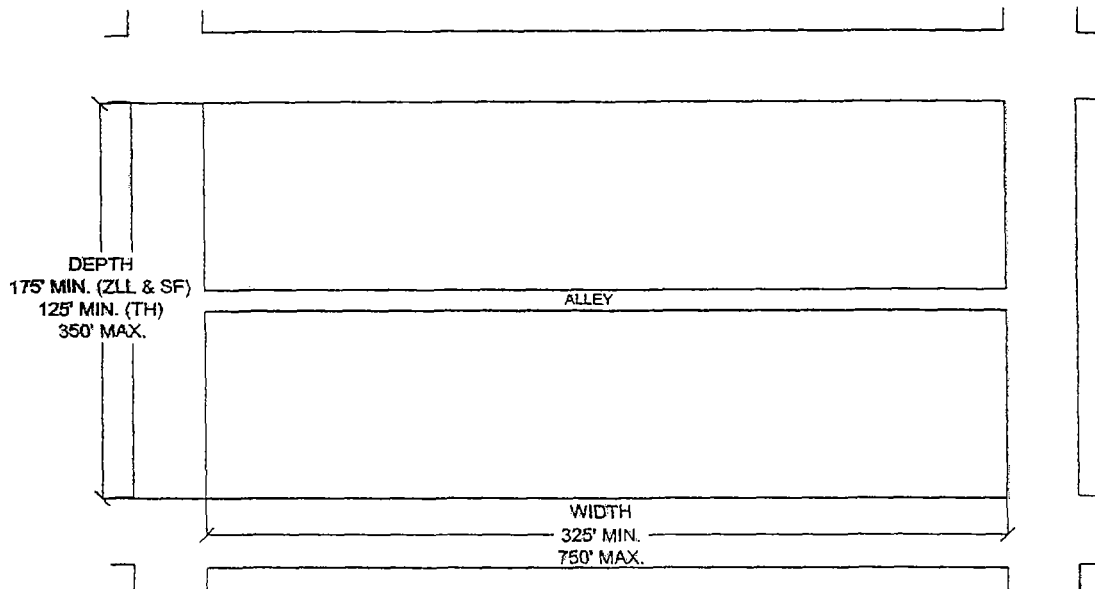
C. Development Standards

1. Shall comply with the PUD standards and requirements in the ULDC.
2. Block Dimensions. (See Figure 3.2)
 - a. Depth
 - (1) Minimum: 125 feet (Townhouse or Multi-Family)
175 feet (Zero-Lot-Line and Single Family)
 - (2) Maximum: 350 feet



- b. Width
 - (1) Minimum: 325 feet
 - (2) Maximum: 750 feet

Figure 3.2 – Residential Block Structure



3. Garage or driveway access shall be provided from alleys for a minimum of 60% of the single family, zero-lot-line, and townhouse residential units.
4. The maximum number of alley curb cuts per block shall be four.
5. Each residential unit shall be located a maximum distance of 1,320 feet from at least one public open space, park, plaza, or green.
6. All public open spaces, BTP Natural Areas, and waterfronts located within a residential pod shall be open and accessible to all residents of said Pod.
7. Attached and detached housing types shall be provided within each residential Pod with a minimum of 20% of the total dwelling units being designated for each type.
8. All multi-family and townhouse development shall include covered parking provisions for low speed electric vehicles for a minimum of 40% of the units, in addition to the minimum ULDC parking requirements, and as consistent with all regional and local Conditions of Approval.
9. All single family and/or zero-lot-line development shall include garage parking provisions for low speed electric vehicles for a minimum of 60% of the units, and as consistent with all regional and local Conditions of Approval.
10. All residential neighborhoods shall be designed in accordance with the nine principles of the Florida Yards and Neighborhoods Program. (Cooperative Extension Service, University of Florida, Institute of Food and Agriculture Sciences in cooperation with the United States Department of Agriculture)

11. Each residential neighborhood shall provide shaded pedestrian connections to the Pedway system to and from each public open space, park, plaza, green, or recreational area.

12. Public Areas

Public Areas in the form of public open space, parks, plazas, greens, squares, or recreational areas are required to provide recreational opportunities for residents and focal points for pedestrians, subject to the following standards:

a. Minimum total area

- (1) 20,000 square feet or five percent of the gross land area within a parcel or Pod, whichever is greater, shall be used for Public Areas.
- (2) The minimum requirement for public areas shall be in addition to any recreation areas required by the ULDC.

b. Minimum Size

- (1) Central Public Area: 20,000 square feet
- (2) Other Public Areas: 10,000 square feet

c. Required Location.

- (1) The Central Public Area shall be bounded by streets on at least three sides.
- (2) Other Plazas and Squares shall be bounded by a street on at least one side.

d. Required Dimensions

- (1) Minimum Length
 - (a) Central Public Area: 120 feet
 - (b) Other Public Areas: 60 feet
- (2) Minimum Width
 - (a) Central Public Area: 80 feet
 - (b) Other Public Areas: 40 feet

e. Required Landscaping and Pedestrian Amenities

- (1) A minimum of 50 percent of the total area of each Public Area shall be shaded by landscaping or shade structures.
- (2) A minimum of 40 percent of the total area of each Public Area shall be pervious area.
- (3) Each Public Area shall provide a minimum of one linear foot of seating for each 200 square feet of overall area.

f. All Public Areas shall be dedicated to and maintained by the Property Owner's Association.

Section 4 Recreation/Civic

A. Purpose and Intent

The purpose and intent of Recreation/Civic Pods are to:

1. Provide recreational areas and other public services to the residents, employees, and visitors of the Research Park and the surrounding community.



B. Uses Allowed

1. Permitted Uses. Shall correspond to those Use Types permitted in the Recreation Pod of a PUD as identified in the ULDC Table 3.E.1.B-10 PDD Use Matrix.
2. Requested Uses. Any Requested Uses shall be subject to BCC approval.

C. Development Standards

1. Shall comply with Recreation pod of PUD standards and regulations as identified in the ULDC Table 3.E.2.D-16 – PUD Property Development Regulations.
2. Public Parks shall comply with Supplemental Regulations in the ULDC.
3. Each public open space, park plaza, green, or recreational area shall provide shaded pedestrian connections to and from the Pedway system.



CHAPTER 4 OPEN SPACE

Section 1 The Pedestrian Mall

A. Purpose and Intent

1. The Purpose and Intent of the Pedestrian Mall is to:
 - a. Create an architectural "display" area.
 - b. Provide an identifiable public gathering space.
 - c. Serve as a central unifying factor for the Research Park.

B. Uses Allowed

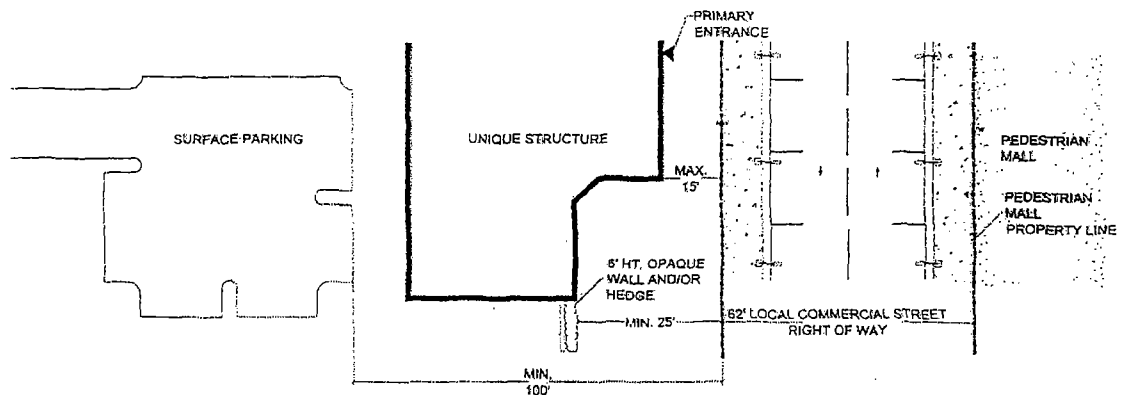
1. Permanent structures shall be permitted on the Pedestrian Mall only after approval by the Property Owners Association and the DRO and subject to the provisions outlined in this Section.
2. Temporary public festivals or other such events may be held on the Pedestrian Mall in accordance with the ULDC.

C. Development Standards

1. Surface parking
 - a. Block Style Development. Surface parking, aside from on-street parking, shall not be permitted within 100 feet of the Pedestrian Mall, measured from the exterior line of the parking area to the edge of right-of-way located closest to the proposed parking area.
 - b. Campus Style Development. Surface parking, aside from on-street parking, shall not be permitted within 100 feet of the Pedestrian Mall, measured from the exterior line of the parking area to that edge of the Pedestrian Mall located closest to the proposed parking area.
 - c. Any surface parking area located within 500 feet of the Pedestrian Mall shall be completely screened from view from the Pedestrian Mall by a 6' height opaque hedge or wall or combination thereof.
2. Berms, opaque hedges, and other forms of screening shall not be permitted within 25 feet of the property line bordering the Pedestrian Mall or the exterior edge of the right-of-way located adjacent to the Pedestrian Mall. (Figure 4.1)

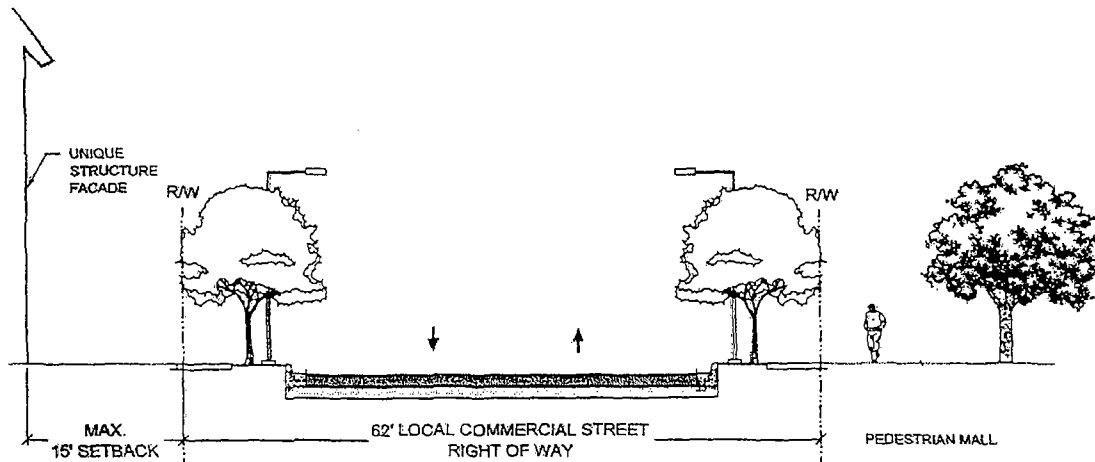


Figure 4.1 – Surface Parking



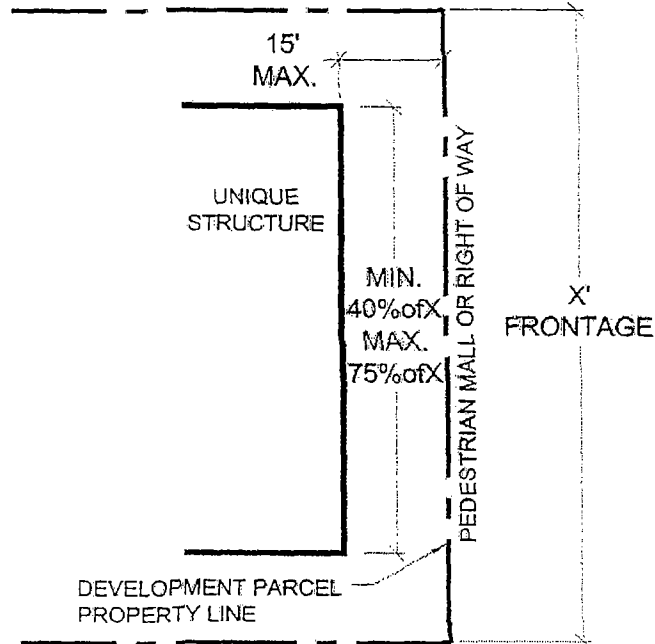
3. Each parcel located adjacent to the Pedestrian Mall, or a right-of-way which is adjacent to the Pedestrian Mall, shall construct a Unique Structure.
4. Each Unique Structure located adjacent to the property line or right-of-way line bordering the Pedestrian Mall shall be setback no more than 15 feet from the Pedestrian Mall property line or exterior right-of-way line, or as otherwise permitted by the BCC. (Figure 4.2)

Figure 4.2 – Unique Structure Setback



5. Each Unique Structure, or combination thereof per pod, located adjacent to the Pedestrian Mall shall provide a facade fronting on the Pedestrian Mall for a length of no less than 40 percent and no greater than 75 percent of the total pod frontage. (Figure 4.3)
6. Primary public entrances to each building located along the Pedestrian Mall shall face the Pedestrian Mall.

Figure 4.3 – Unique Structure Frontage



7. Fences, gates, walls, berms or other barriers shall not be permitted along the Pedestrian Mall, unless approved by the DRO.
8. No modifications shall be made to the Pedestrian Mall without approval from the Property Owners Association.
9. A Final Site Plan for the Pedestrian Mall shall be approved by the DRO.

Section 2 The Promenade

A. The Purpose and Intent

1. The Purpose and Intent of the Promenade is to:
 - a. Create an opportunity to provide a public meeting space for public events or recreational activities.

B. Uses Allowed

1. Permanent structures shall be permitted on the Promenade only after approval by the Property Owners Association.
2. Temporary public festivals or other such events may be held on the Promenade in accordance with ULDC requirements.

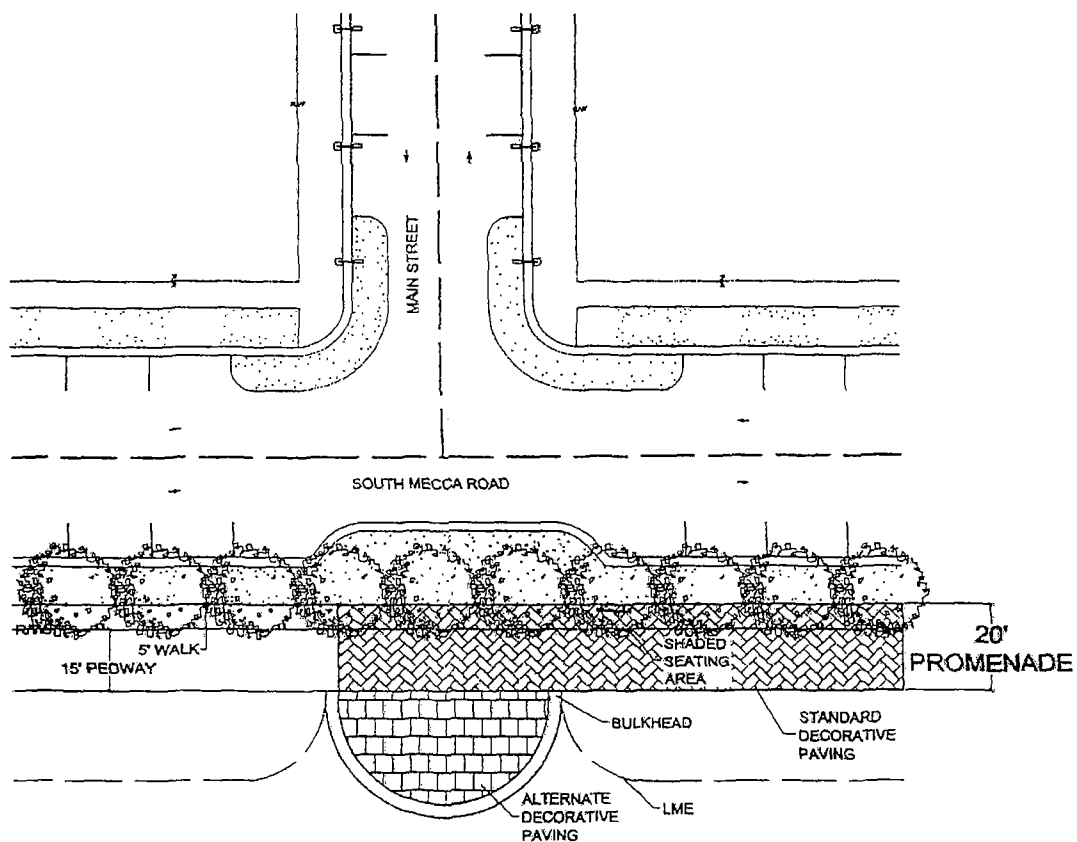
C. Development Standards (Figure 4.4)

1. The Promenade shall be located between the South Mecca Road right-of-way and the southernmost lake.
2. The Promenade shall be a minimum of 20 feet wide, including sidewalk and Pedway.



3. The Promenade shall be a minimum length of 2,640 feet, extending east from the terminus of Main Street for a minimum of 2,240 feet and extending west for the terminus of Main Street a maximum of 400 feet, and shall include the Recreational Amenity located at the terminus of Main Street, as indicated on the BCC Approved Master Plan.
4. The ground surface of the Promenade shall be of a decorative paved material, compatible with the surrounding architecture.
 - a. Paving material may vary to identify various areas (ie: locations of recreational amenities).
5. The Promenade shall be continuously open to and accessible by the public, with exception given to special events or construction activities.
6. The northern edge of the adjacent lake shall be constructed with a bulk head for a minimum of 20% of the length of the Promenade and shall include the Recreational Amenity located at the terminus of Main Street.
7. A minimum of one shaded seating area shall be provided along the Promenade for each 500 feet.
 - a. Seating areas may include benches, bulkhead walls, or other seating opportunities, as approved by the DRO.
 - b. A Final Site Plan for the Promenade shall be approved by the DRO.

Figure 4.4 – The Promenade



Section 3 The BTP Natural Area

A. Purpose and Intent

1. The Purpose and Intent of the BTP Natural Areas are to:
 - a. Provide a recreational wetland system to enhance the quality of the surrounding environmental areas.
 - b. Foster the establishment of wildlife habitat and serve as an environmental education area.

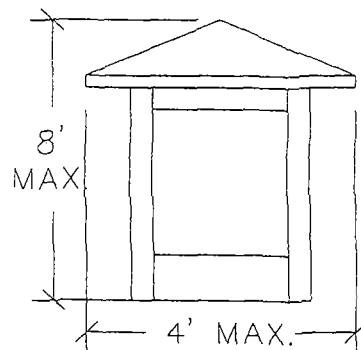
B. Uses Allowed

1. Permitted Uses. Passive recreational uses such as, but not limited to, canoeing, kayaking, hiking, or equestrian trails.
2. Requested Uses. Any Requested Uses shall be subject to BCC approval.

C. Development Standards

1. No permanent structures shall be erected within the designated BTP Natural Area, except for informational kiosks, canoe/kayak launch sites, and trailheads, unless approved by the Property Owners Association and Palm Beach County Department of Environmental Resource Management (ERM).
2. Informational kiosks: (Figure 4.5)
 - a. Shall be provided along the hiking trails and at any trailheads or launch sites.
 - b. Shall inform and educate users as to the sensitive nature of the environmental area.
 - c. Shall be no greater than 8 feet in height and 4 feet in width.
 - d. Shall be constructed of materials which maintain the appearance/look/feel of "natural" materials.
 - e. Shall be designed in such a way as to protect the surrounding area from resulting debris or litter. Example - if flyers or posters are used then they shall be enclosed in a locked case or display made of shatterproof glass or other transparent material.
 - f. Shall include a minimum of one (1) trash receptacle.

Figure 4.5 – Kiosks



CHAPTER 5 TRANSPORTATION

Section 1 Streets

A. Purpose and Intent

1. The purpose and intent of the Transportation systems are to:
 - a. Provide a safe and efficient vehicular transportation system to connect all areas of the Research Park.
 - b. Provide safe and efficient vehicular connections to the surrounding communities.
 - c. Provide a hierarchical street classification system in order to accommodate the various needs of the users as well as to assist in lessening traffic congestion by providing a variety of route options.
2. Development Standards
 - a. General
 - (1) All vehicular use and service areas (surface parking, loading/unloading areas, dumpsters, etc.) shall be screened from view of Primary, Secondary, and Tertiary streets by landscaping or buildings/structures to a height of six feet.
 - (2) Appropriate corner clips, visibility triangles, and sight corners as required by the ULDC and the PBC Engineering Standards shall be provided.
 - b. Primary Streets
 - (1) Primary Streets shall serve as arterial roadways within the Research Park and will include:
 - (a) PGA Boulevard – 260' right-of-way (Figure 5.1)
 - (b) Seminole Pratt Whitney Road – 180' right-of-way (Figure 5.2)
 - (2) Direct access to pods or parcels shall not be obtained from Primary Streets, with the exception of PGA Boulevard slip roads and Pods D, H, and I, as approved by the County Engineer.

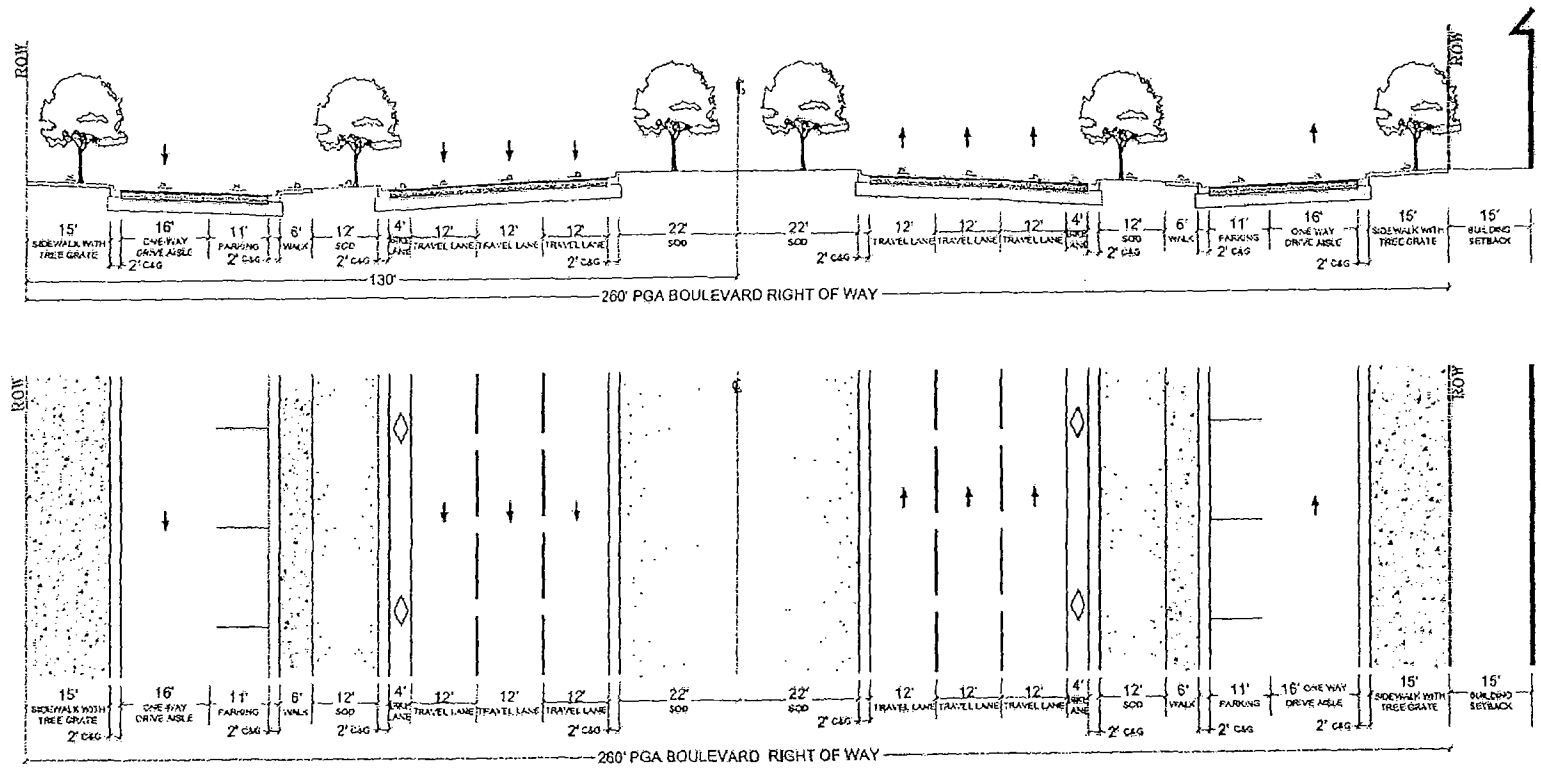


Figure 5.1 – PGA Boulevard 260' Right-of-Way Cross-Section

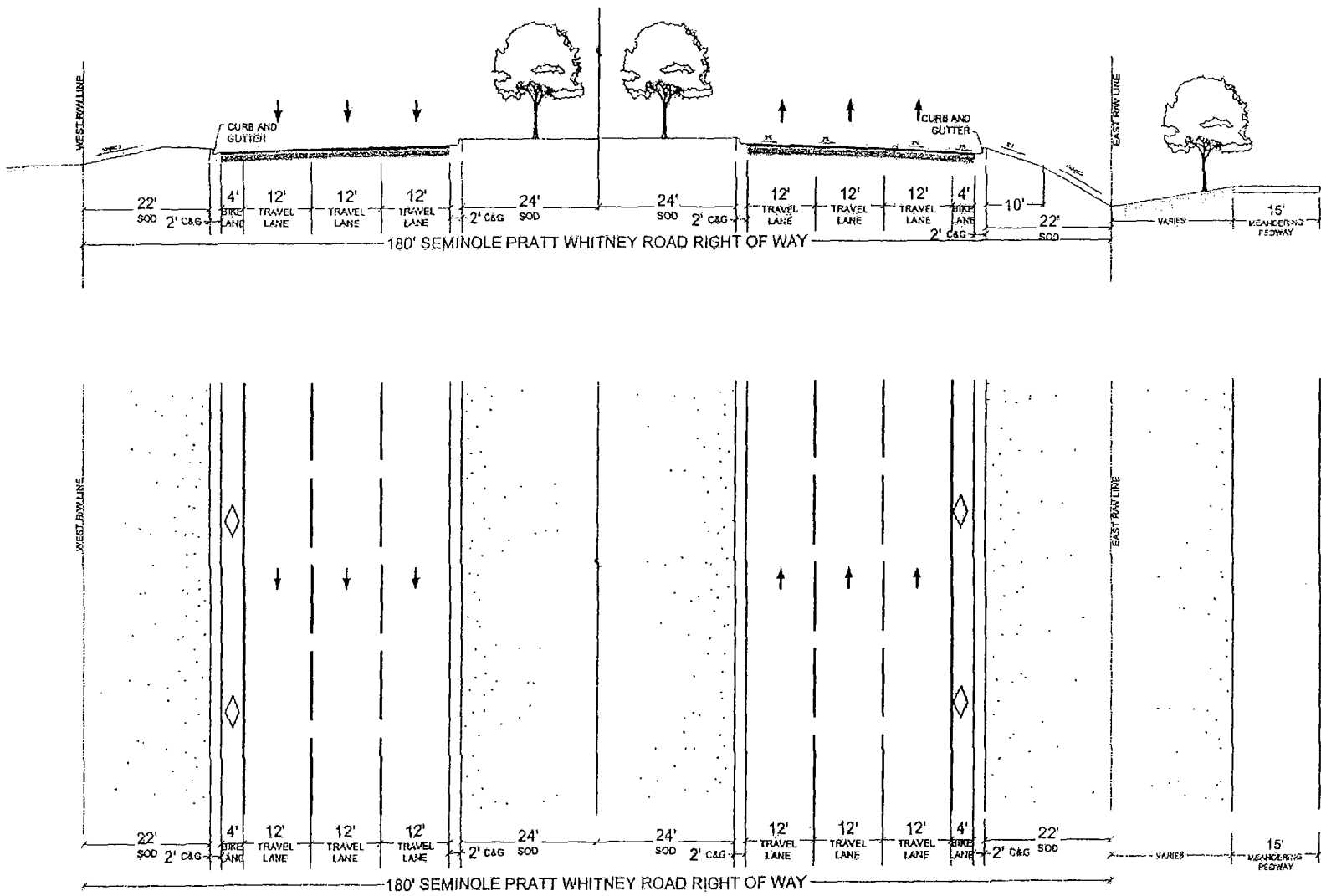


Figure 5.2 - Seminole Pratt Whitney Road 180' Right-of-Way Cross-Section

c. Secondary Streets

- (1) All 120' right-of-way collector streets (Figure 5.3)
- (2) All 80' right-of-ways (Figure 5.4)
- (3) Secondary streets may provide direct access to development Pods or parcels.

Figure 5.3 – Secondary (Collector) Street 120' Right-of-Way Cross-Section

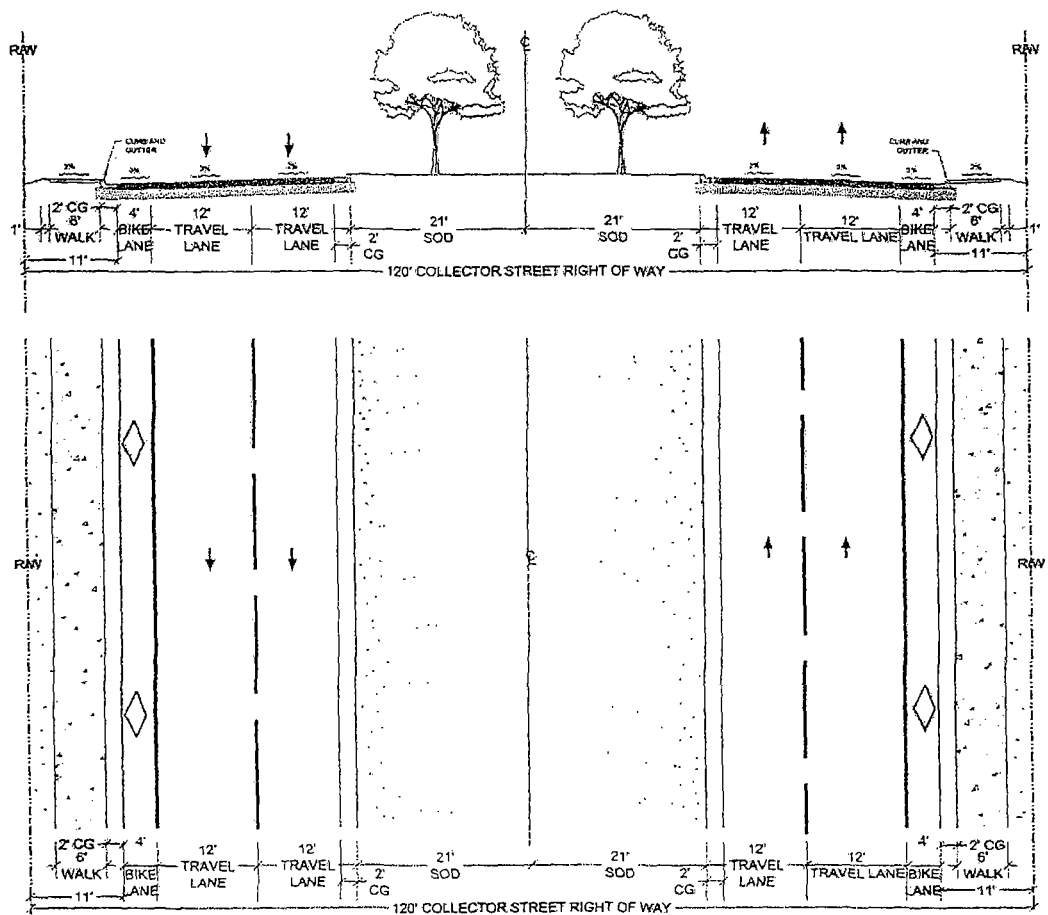
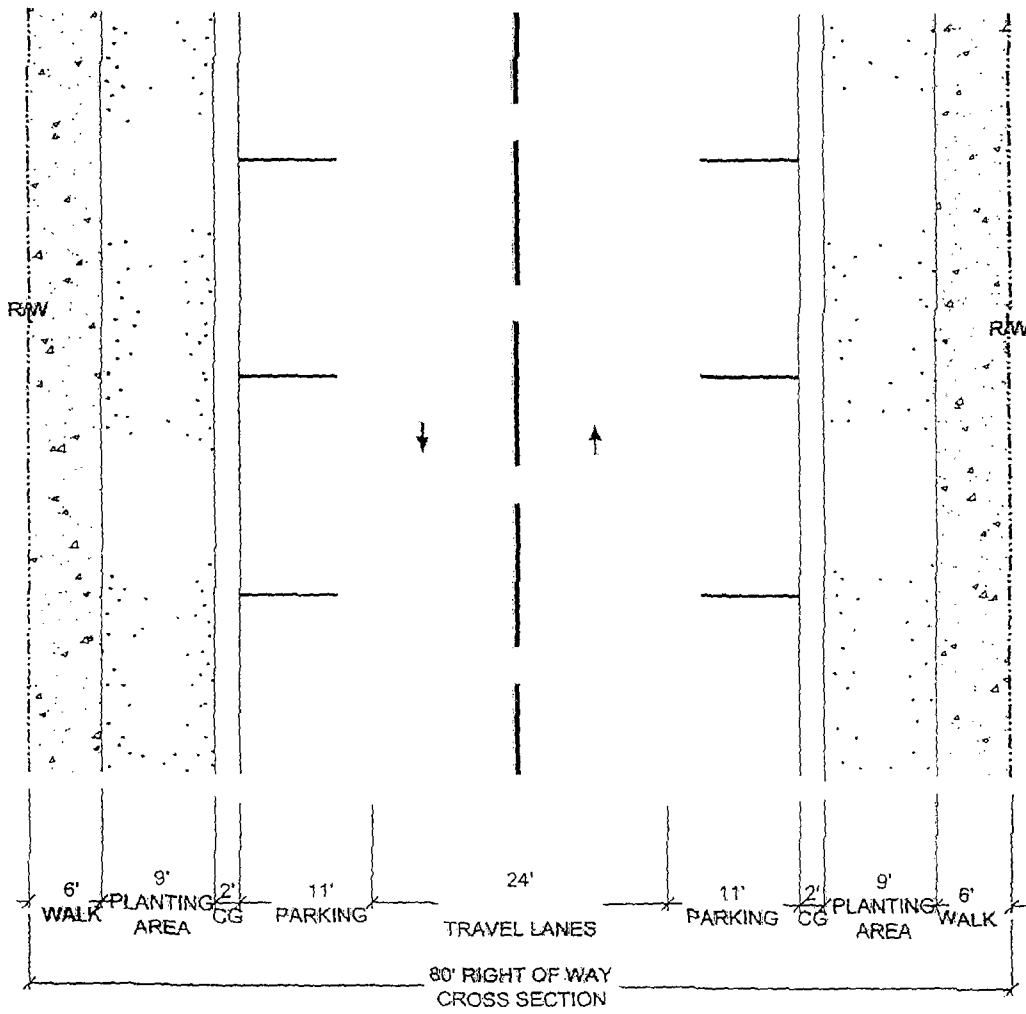
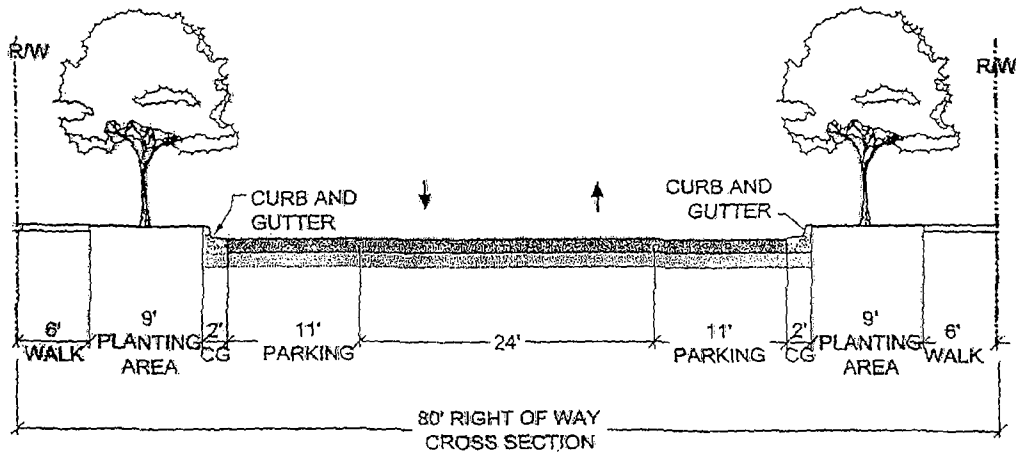


Figure 5.4 –Secondary Street 80' Right-of-Way Cross-Section with On-Street Parking



d. Tertiary Streets

- (1) Local Commercial Streets – 62' right-of-way (Figure 5.5)
- (2) Local Residential Streets – 62' right-of-way (Figure 5.6)

Figure 5.5 –Local Commercial Street (Tertiary) 62' Right-of-Way Cross-Section

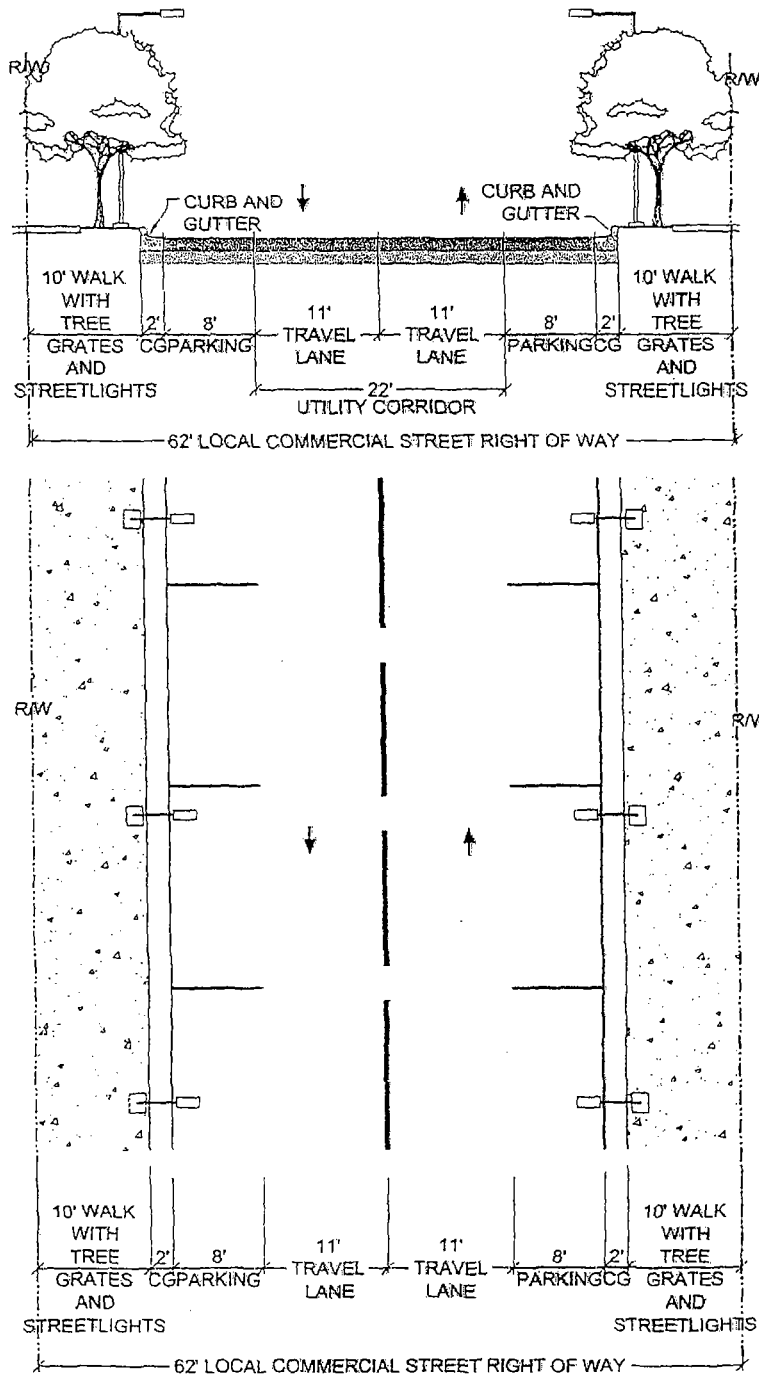
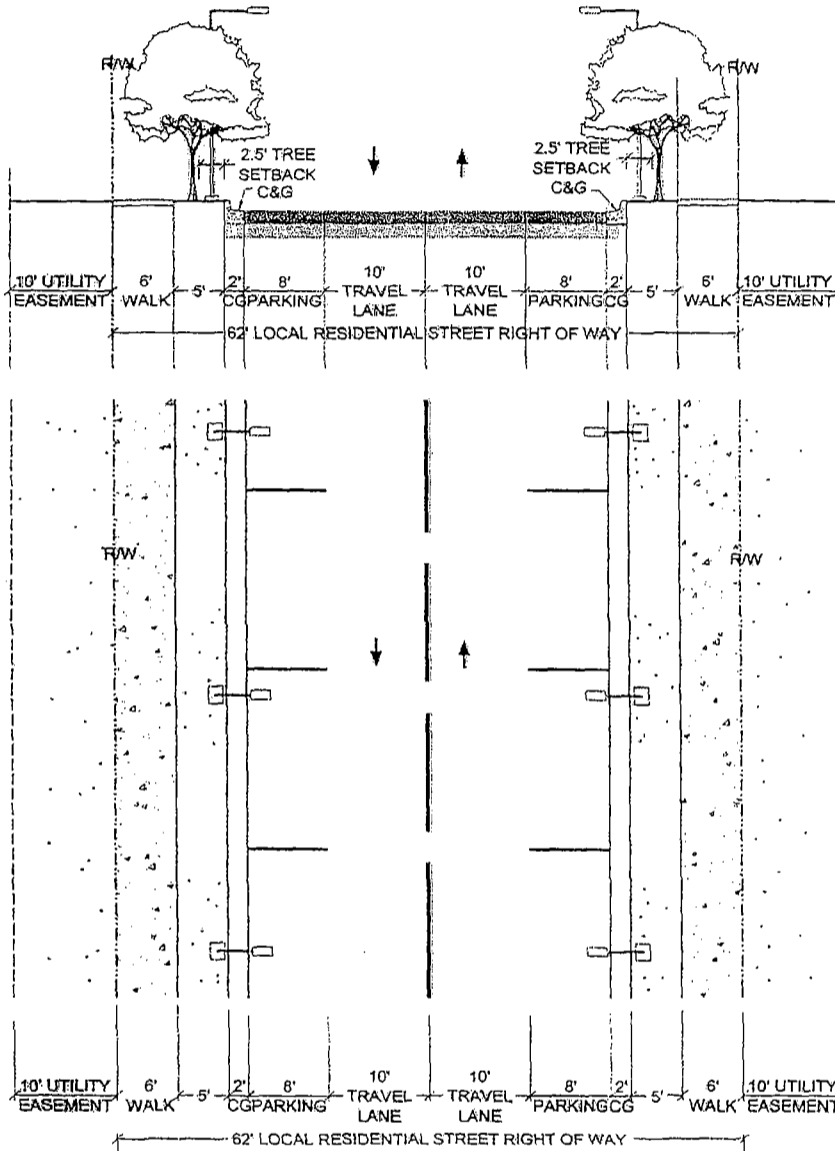


Figure 5.6 –Local Residential Street 62' Right-of-Way Cross-Section



e. Alleys (Figure 5.7)

(1) One-Way (Residential Use only)

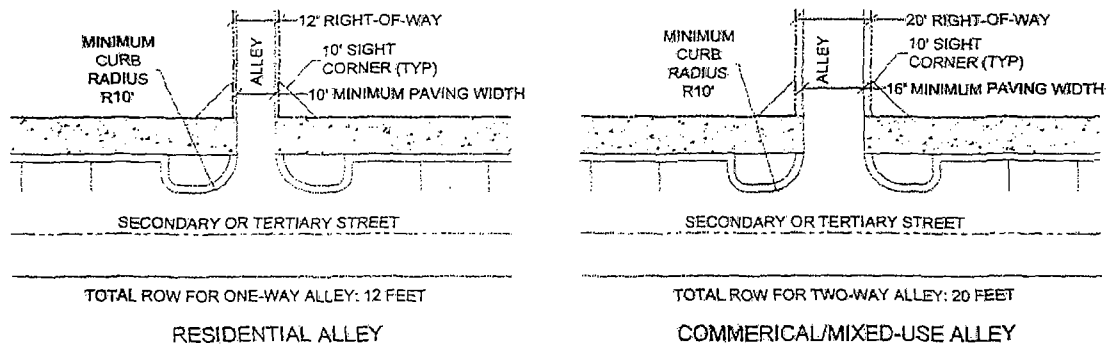
- (a) Minimum right-of-way: 12 feet
- (b) Minimum paving width: 10 feet
- (c) Minimum curb radius: 10 feet

(2) Two-Way

- (a) Minimum right-of-way: 20 feet
- (b) Minimum paving width: 16 feet
- (c) Minimum curb radius: 10 feet

(3) A 10 foot sight corner shall be provided at each intersection of an alley and a street right-of-way.

Figure 5.7 –Alley Design Standards



Section 2 Pedestrian Systems

A. Purpose and Intent

The purpose and intent of the Pedestrian Systems are to:

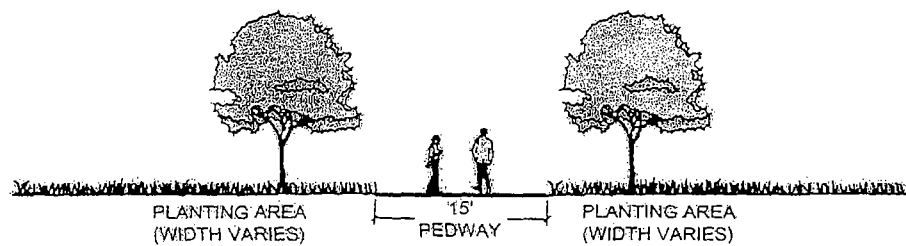
- a. Provide an alternative to single occupant vehicles by providing a variety of transportation options.
 - b. Provide recreational opportunities.
1. Pedway System (Figure 5.8)
 - a. Permitted transportation devices.
 - (1) Man-powered transportation devices, including but not limited to: bicycles, rollerblades, pedestrians, etc.
 - (2) Electric personal assistive mobility devices, as permitted by Section 316.2068, Florida Statutes.
 - b. Prohibited transportation devices.
 - (1) Gas-powered vehicles.
 - (2) Low Speed Electric Vehicles as defined in Section 320.01, Florida Statutes.
 - c. Development Standards
 - (1) The Pedway shall be a paved surface, to meet or exceed Palm Beach County Parking Lot Standards, except as indicated otherwise on the BCC Approved Master Plan.
 - (2) The Pedway shall be a minimum width of 15 feet.
 - (3) The Pedway shall be continuously open to, and easily accessible for, public use.
 - (4) Any modifications to the Pedway System shall be approved by the Property Owners Association.
 - (5) The Pedway shall remain as a continuous system which shall provide public access to all areas of the Research Park.
 - (6) Each development parcel (including each individual user within a Pod) shall provide unimpeded public access to and from the Pedway System. Exceptions to this requirement may be granted by the Property Owners Association provided that the applicant can



provide evidence to support such a request. If such an exception is granted then the applicant shall provide alternative access to the Pedway System, which shall be approved by the Property Owners Association.

- (7) The Pedway System shall be shaded as required by Chapter 7 of this document.

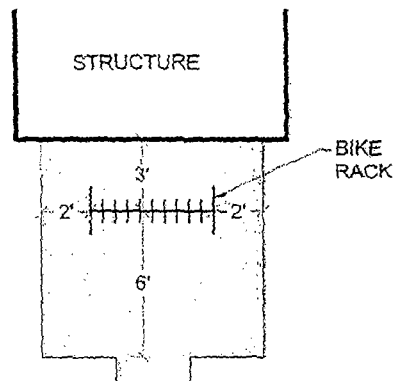
Figure 5.8 – Pedway System



2. Sidewalks
 - a. All sidewalks within right-of-ways shall be interconnected with the Pedway System.
 - b. Traffic control devices shall be provided at all intersections to facilitate pedestrian movement across streets.
 - c. All sidewalks shall have a minimum width of 5 feet and be constructed of a paved surface.
 - d. All sidewalks shall be shaded by canopy trees, pursuant to Chapter 7 of this document.
3. Bicycles
 - a. Bicycle lanes shall be provided along PGA Boulevard and Seminole Pratt Whitney Road and shall be a minimum width of four (4) feet.
 - b. Bicycle parking shall be provided as follows:
 - (1) One bicycle rack for every five (5) units of attached housing.
 - (2) One bicycle rack for every 20 vehicle parking spaces serving non-residential uses.
 - c. To accommodate each required bicycle parking space, permanent bike racks shall be provided to which a user can secure a bicycle.
 - (1) The bike rack shall be located on a paved area that shall be a minimum of four feet wider than the bike rack (measured two feet from each end) and extend a length of no less than six feet measured perpendicular to the bike rack, as illustrated in Figure 5.9.



Figure 5.9 – Bicycle Parking



4. Hiking Trails

- a. A pedestrian hiking trail shall:
 - (1) Be provided along the west side of Seminole Pratt Whitney Road.
 - (2) Connect to the Pedway System.
 - (3) Provide access to a trail head in the northwest corner of the Research Park to the BTP Natural Area and to the JW Corbett Wildlife Management Area.
- b. The hiking trail system shall include a minimum of four (4) informational kiosks, spaced at a minimum distance of 500 feet apart. Information kiosks shall:
 - (1) Be constructed of materials which appear "natural" and are not harmful to the environment.
 - (2) Be used to provide educational information to the public regarding the surrounding environmental areas, such as habitat and wildlife, and any existing protection efforts.
 - (3) Include a minimum of one (1) trash receptacle each.

5. Equestrian Trails

- a. An equestrian trail shall be provided along the western edge of the Research Park to connect to the JW Corbett Wildlife Management Area and existing and proposed equestrian trails in the surrounding community.
- b. Equestrian Trails shall be designed in accordance with the Palm Beach County Departments of Environmental Resources Management and Parks and Recreation standards.



Section 3 Alternative Vehicular Systems

A. Purpose and Intent

1. The Purpose and Intent of Alternative Vehicular Systems are to:
 - a. Encourage the utilization of a public transit system within the Research Park, including, but not limited to; bus service or a rubber tire trolley system.
 - b. Promote ride sharing by public and private sector employees.
 - c. Promote effective coordination among various modes of transportation.
 - d. Increase access to and use of alternatives to the single-occupant vehicle.

B. Low Speed Electric Vehicles

1. Pursuant to Section 316.2122, Florida Statutes, Low Speed Electric Vehicles may operate on streets with a posted speed limit of 35 miles per hour or less.
2. Low Speed Electric Vehicles may operate on all Tertiary Streets in the Research Park, as well as any other streets with the appropriate posted speed limit and may cross over any streets.
3. Low Speed Electric Vehicles may not operate on the Pedway.

C. Transportation Demand (TDM) Strategies

The following approach shall be used to promote ride sharing by employees. This approach will help lessen the impact of peak periods of traffic, allow costly roadway improvements to be minimized, strengthen the community fabric, increase mobility choices, connect the Research Park to a wider region, and elevate the uniqueness and marketability of the Research Park.

The following strategies shall be utilized:

1. Provide facilities for the posting of TDM Program Information in a location that is readily visible to employees, including information kiosks, direct distribution of information, and providing South Florida Commuter Services (SFCS) presentations on ridesharing programs.
2. A minimum of two of the following incentives shall be provided by each tenant within the Research Park for employees who make work trips by modes of transportation other than single occupant automobiles:
 - a. Offer preferred parking spaces.
 - b. Provide discounts to property amenities (ie: cafeterias, retail shops, automotive services, gyms, dry cleaning, cable packages, etc.) at regular and continuous intervals.
 - c. Provide random give-a-ways (ie: sporting event tickets, movie tickets, gift certificates, gas cards, etc.)
 - d. Provide SunPass transponders and subsidies to carpools or vanpools.
 - e. Provide discounts on association or professional membership fees.
 - f. Provide shower facilities for bikers or other pedestrian travelers.
 - g. Provide free valet parking.



- h. Offer compressed work schedules, flextime, or teleworking to employees.
- i. Provide free DSL service to employees who telework.
- j. Provide discounts for Palm Tran or other mass transit passes.

D. Transit and Transportation Demand Management

1. A Transit Master Plan shall be prepared in consultation with Palm Tran, Florida Department of Transportation, the Palm Beach County Metropolitan Planning Organization, and the South Florida Regional Transportation Authority. The plan shall describe and address the following:
 - a. Plans for a fixed-route commuter (Palm Tran) transit system serving the site from the surrounding commuter area. At a minimum, the system shall identify optimum bus routes and commuter circulation routes within the limits of the following area: Indiantown Road to the north; Seminole Pratt-Whitney Road to the west; US 1 to the east; and Okeechobee Boulevard to the south.
 - b. Continued coordination with the South Florida Regional Transit Authority for a Tri-Rail station at PGA Boulevard and Beeline Highway and transfer station and facilities accommodating fixed-route shuttle services to and from the station and the Palm Beach County Biotechnology Research Park.
 - c. Continued coordination for an on-site, community based (shuttle/trolley) circulator system.
 - d. To strive for the optimal characteristics of a fixed route (Palm Tran) transit and community based (shuttle/trolley) circulator system. Such a system should consider:
 - (1) A recommended requirement that all structures be within a ¼ mile of a bus stop with unrestrictive pedestrian access.
 - (2) Community Circulator service should be provided for movement within the site and interconnected with the fixed-route service and the intermodal center.
 - (3) Ideal headways for the system.
 - (4) Financing and costs associated with implementing the recommended system.
 - (5) The location (spacing), timing, size, and appearance of transit stops and stations as well as details facilitating integration of transit stops with adjacent development.
 - e. Several different types of bus stops shall be addressed, including neighborhood, transfer, and hub:
 - (1) Neighborhood stops should be at locations such as schools or large employers or stops having more than 10 average daily boardings. These stops shall include a shelter, bench, sign with schedule and trash receptacle, and be consistent with the Palm Tran Design Standards Manual.



- (2) Transfer stops should be at locations with over 25 average daily boardings or locations where more than one transit route interface. These stops shall include a shelter, bench, sign with system information, trash receptacles, lighting, and bicycle rack, and be consistent with the Palm Tran Design Standards Manual.
 - (3) Hub stops should be at locations with over 50 average daily boardings a day and multiple transit routes. These stops shall include a shelter, bench, sign with system information, trash receptacles, lighting, bicycle rack, and newspaper vending, and be consistent with the Palm Tran Design Standards Manual and subject to review by Palm Tran.
2. In order to ensure economic opportunity and modal choice for the entire community, fixed route transit, including night and weekend service, is encouraged to be extended to the Research Park. A minimum 30-minute peak period headway is desirable. Every reasonable effort should be made to accommodate non-standard work hours.
 3. Construction of the Intermodal Center shall commence with the first building permit for Pod O and shall include, at a minimum, the following characteristics:
 - a. Accommodation for Palm Tran buses and Community Shuttles (Intermodal connections)
 - b. Shelter (convenience)
 - c. System schedule information (convenience)
 - d. Trash receptacles (convenience)
 - e. Lighting (safety)
 - f. Bicycle facilities (Intermodal connections)
 - g. Seating (convenience)

A site plan for the Intermodal Center shall be approved by the DRO. FDOT District Office 4 shall have the opportunity to review and comment on the site plan and construction documents for the Intermodal Center.
 4. All development pods or parcels shall incorporate parking and transit strategies into their site plans that:
 - a. Maximize access to community shuttle and transit stops
 - b. Maximize the use of pedestrian facilities and connectivity to the Pedway System
 - c. Limit individual parking lots for individual facilities
 - d. Promote aggregate parking for multiple uses
 - e. Promote shared parking (e.g. daytime vs. nighttime activities)
 - f. Provide preferential parking for van pool, car pool, and alternative fuel vehicles
 - g. Promote a "park once" strategy.
 - h. Orient buildings and their main entrance toward streets to create better pedestrian environments.
 - i. Locate buildings so they are as convenient and accessible to public transportation facilities and sidewalks as they are to automobile parking.



- j. Locate parking to the sides and backs of buildings so that pedestrian access and access from public transportation does not require walking through large parking lots to reach building entrances.
- k. Design and locate parking lots and garages to enhance "pedestrianism" and the character and attractiveness of the area, and to encourage use of alternate modes of transportation.



CHAPTER 6 ARCHITECTURE

Section 1 Purpose and Intent

- A. The Purpose and Intent of the Architectural Guidelines are to:
1. Encourage development to contribute to the Research Park as a unique, "world-class" development by enhancing the built environment with building that are distinct and original.
 2. Throughout the development there will be common elements and design theme (styles) moving from one Pod to the next. The buildings will draw users towards the center of the development, to use and view its Unique Structures along the Pedestrian Mall.

Section 2 Applicability

- A. This chapter shall apply to the following structures:
1. All non-residential structures.
 2. All residential structures.
- B. Exceptions
1. The first three structures in Phase 1 of Pod N.
 2. Buildings which are exempt from local building permits or government review pursuant to State of Florida or Federal Statutes, except for Unique Structures.
 3. Utility sites that do not front on a Primary or Secondary street and are screened from view.
 4. Accessory Structures.

Section 3 Design Elements

- A. General
1. The unified architectural character and image for the Research Park shall be created by the use of common elements, such as consistent forms, colors, materials, and details.
 - a. Along the Pedestrian Mall, Unique Structures will be focal points and works of art within the development.
 - b. In Industrial Pods not adjacent to the Pedestrian Mall, buildings may be "object buildings within the landscape."
 2. Similar architectural composition and treatment shall be provided on all sides of each building contiguous to a public street or open space.
 3. Accessory buildings within a project shall be constructed of compatible materials, colors, and character as the principal building.

4. All electrical, air conditioning, and fixed mechanical equipment, including satellite dishes, shall be screened from view on all sides by an opaque barrier constructed of compatible materials, color, and character of the structure, or equivalent landscaping.

B. Residential

1. A Master Development Plan, as required by these Design Standards, for each Residential pod shall be approved by the Property Owner's Association and be provided at time of final site plan approval by the DRO.
 - a. The Master Development Plan is comprised of the following information:
 - (1) Representative building elevations for each unit type (ie: single family, zero-lot-line, townhouse, multi-family, etc.).
 - (a) Elevations are not required for each unit but should demonstrate the overall design concept/theme for each unit type.
 - (2) Building materials and colors.
 - (3) Building elevations for common area structures.
 - (4) Floor Plans
 - (5) Focal Point details.
 - b. Provide an overall design theme for residential structures through the use of consistent and compatible colors, materials, and/or design style within each Pod or Phase of development.
 - c. Include a minimum of one of the following elements for a minimum of 60% of the units, per Pod:
 - 1) Front porches or terraces, no less than 100 square feet.
 - 2) Balconies or upper terraces, no less than 100 square feet
 - 3) Combination of 1) and 2), not less than 100 square feet total.
 - d. Provide sidewalks from the street to the front door.
 - d. Garage or driveway access shall be provided from alleys for a minimum of 60% of the single family, zero-lot-line, and townhome residential units.
 - e. To encourage architectural diversity, no less than seven typical units shall be provided for detached housing and no less than four typical units for attached housing, per Pod.
 - f. Identical buildings may not share the same property line.
2. Deviations from Property Owners Association approval.
 - a. Any deviations from materials or colors approved by the Property Owners Association may be approved by staff in the following instances:
 - (1) Materials are of a similar appearance and texture.
 - (2) Colors are within the same range and do not vary by more than 3 shades from those approved.
 - b. Minor modifications may be made to building elevations provided that the overall theme or design remains the same.
 - c. All other deviations shall be re-reviewed by the Property Owners Association.



- d. Any deviations may be required to be re-reviewed by the Property Owners Association at the discretion of staff.

Section 4 Unique Structures

A. In addition to the requirements of the ULDC, the following standards shall apply:

1. Review Process

- a. All Unique Structures shall be reviewed and approved by the BCC prior to final approval of a site plan.
- b. *Unique structures shall be identified on the Site Plan.*

2. Application Contents.

In addition to the Architectural Guidelines application and Visual Impact Analysis as outlined in the Supplementary Standards of the ULDC, the application shall be supplemented with the following information:

- a. Design Statement.

A document written by the design professional, which articulates the conceptual design aims and intentions set out for the Unique Structure; analyzes the site conditions, land development requirements, and how each is fulfilled and satisfied in the building and site design.

- b. Architectural Floor Plans

- c. Landscape Plans

Application to be consistent with the requirements within the Landscape section of the ULDC.

3. Standards.

The BCC shall consider the following standards:

- a. Design Elements:

- (1) Varied Forms
- (2) Rhythm
- (3) Light
- (4) Views
- (5) Location
- (6) Mass
- (7) Lines
- (8) Materials, textures, and colors.
- (9) Quality workmanship

- b. Expression

The proposed architectural composition is a significant work of art, both inspirational and contemplative in spirit, and a coherent expression and realization of design philosophy.

- c. Exemplary Quality

The proposed architectural composition evidences quality materials, workmanship, detailing, building systems and processes, overall design, and reinforces a standard of excellence.

- d. Unity of Design



The proposed architectural composition and its elements reflect an integrated design aesthetic and include, but are not limited to, dumpsters, site lighting, pedestrian amenities, waste receptacles, kiosks, signage, etc.

Section 5 Green Building

A. Purpose and Intent

1. To encourage development that makes efficient use of, and minimizes impact on, limited environmental resources, and minimizes negative environmental impacts on the surrounding area.
2. The purpose is not to require certification from the US Green Building Council (USGBC) Leadership in Energy and Environmental Design (LEED) Rating System, but to encourage and promote green building and sustainable design within the Research Park by utilizing their, and others, standards.

B. Exemptions

1. Utility Sites located within Pod S, as identified on the BCC Approved Master Plan.
2. The first three structures in Phase 1 of Pod N.
3. Buildings that are exempt from local building permits or government review pursuant to State of Florida or Federal Statutes, except for Unique Structures.
4. Residential Structures

C. Application/Review

1. At the time of submission for Final Site Plan Approval, the applicant shall submit a report, in a form established by the Zoning Director, identifying which LEED Rating System elements have been utilized.
 - a. The Development Review Officer may impose conditions on the site plan approval establishing which criteria have been met with the site plan approval and the number of points remaining which shall be identified at time of Building Permit submittal.
2. At time of submission for the first Building Permit, the report shall be updated and submitted to the Building Department to identify any remaining elements of the LEED Rating System in order to meet the minimum required number of points.

Section 6 Additional Conservation Strategies

- A. To the extent feasible, the project is encouraged to utilize ultra-low volume water-saving plumbing fixtures, self-closing and/or metered faucets, and other water conserving devices as specified in the Water Conservation Act, Section 553.14, Florida Statutes, to reduce water use for future project development. These devices and methods shall meet the criteria outlined in the water



conservation plan of the public water supply permit issued to Palm Beach County Water Utilities Department by the South Florida Water Management District.

- B. The final site and building designs shall comply with Florida Thermal Efficiency Code Part VII, Chapter 552, Florida Statutes. To the maximum extent feasible, the project shall also incorporate measures identified in the Treasure Coast Regional Planning Council's energy guide entitled, *Energy Planning in the Twenty-First Century: A Guide for Florida Communities*, updated January 2003; and the RPC Strategic Regional Policy Plan.
- C. The property owner shall encourage incorporation of each of the 17 energy saving methods outlined in the appendix of the Treasure Coast Regional Planning Council's Assessment Report for the Research Park unless it can be demonstrated to the satisfaction of Palm Beach County that individually, each method is not cost effective.

Section 7 Site Furnishings

A. Purpose and Intent

- 1. The purpose and intent are to establish standards for the placement, use, and design of site furnishings within the Research Park in order to maintain its intended character and aesthetic appeal.

B. General

- 1. All site furnishings located within or within view of public areas shall be of a consistent color, material, and style, as approved by the Property Owners Association.
- 2. Site Furnishings Plan
 - a. A Site Furnishings Plan shall be approved by the Property Owners Association and shall include the following:
 - (1) Details and Specifications for each type of site furnishing to be provided within the Research Park, including but not limited to: benches, trash receptacles, bicycle racks, drinking fountains, newspaper vending machines, tables, tree grates, water features, etc.

C. Art in Public Places

1. General

- a. The design and location of any piece of artwork, publicly or privately funded, which is proposed to be located on publicly owned property shall be submitted for review and recommendation to the Public Art Committee of Palm Beach County's Art in Public Places program, and approved by the Property Owners Association.



- b. The design and location of any piece of artwork that is proposed to be located on privately owned property visible to the general public shall be approved by the Property Owners Association.
2. Publicly Funded Art
- a. The Public Art Committee of Palm Beach County's Art in Public Places program shall set the direction and conduct the selection of public art on County property where projects are sited.
 - b. Commissioned works of art, whether loaned donated, or purchased, shall result from a dynamic interaction between selected artists, architects, landscape designers, site user groups, and interested constituent groups.
 - c. Artistic elements shall be integrated into the planning, design, and engineering process of projects on County property.
 - d. Artwork will be sited as an integral part of the construction project.
 - e. Siting shall be subject to approval by Palm Beach County's Public Art Committee, in consultation with representative users from the project's facility.
 - f. Public art shall complement the project's buildings, landscapes, and plazas; create a sense of place, enhance community identity, and improve the design quality of regional development.
3. Privately Funded Art
- a. Developers of each parcel are encouraged to provide art as part of their development program.
 - b. Artwork shall complement the project's buildings, landscapes, and plazas; create a sense of place, enhance community identity, and improve the design quality of regional development.



CHAPTER 7 LANDSCAPE

Section 1 Purpose and Intent

- A. The Purpose and Intent of the Landscape standards are to:
1. Create an overall landscape concept for the Research Park by utilizing compatible and complementary plant material and landscape elements.
 2. Further the overall vision for the Research Park by improving the overall appearance and benefits to the users.
 3. Further the environmental objectives of the Research Park.

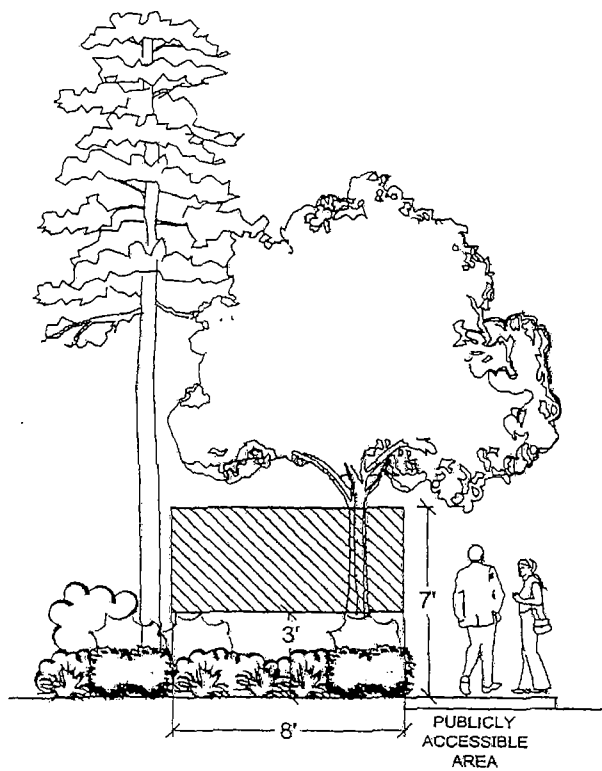
Section 2 General

- A. Design Standards
1. Native Plant Material
 - a. Within common areas, a minimum of 90% of the landscape material required by the ULDC or by BCC Conditions of Approval shall be Florida native, and as consistent with all Regional and Local Conditions of Approval.
 - b. Within all other areas of the Research Park, a minimum of 75% of the landscape material required by the ULDC or by BCC Conditions of Approval shall be Florida native, and as consistent with all Regional and Local Conditions of Approval.
 2. Landscape areas shall be designed to be compatible with, and enhance, the architectural character and features of structures.
 3. Canopy trees shall be provided along all pedestrian paths or walks, including the Pedway.
 - a. Canopy trees shall be located 25 feet on center.
 4. Landscaping shall not be designed in a manner that creates hiding places by interfering with a pedestrian's clear visibility.
 - a. Landscape located adjacent to pedestrian paths shall provide clear views for a minimum distance of 8 feet, measured from 36 inches above grade to a height of 7 feet. (See Figure 7.1)
 5. Landscape elements may be used to direct or frame views of Unique Structures through the creation of an Alternative Landscape Plan.
 6. Landscaping shall be provided around the perimeters of all off-street surface parking areas in order to completely screen them from view from adjacent public areas.
 7. Canopy trees shall be provided within surface parking areas to provide shade as well as to minimize the visual impact of the parking area on the surrounding public areas or structures.



8. Tree grates shall be utilized when trees are provided in paved pedestrian areas (ie: along sidewalks in the Town Center).
9. The utilization of recognized South Florida Water Management District xeriscape concepts is required.
10. Irrigation systems shall utilize water conservation measures, such as rain sensors and drip irrigation, for trees and shrubs.
11. For public areas and along roads, Bahia species or other durable, drought-resistant turf, is encouraged.

Figure 7.1. – Clear Pedestrian Visibility



CHAPTER 8 PARKING

Section 1 Purpose and Intent

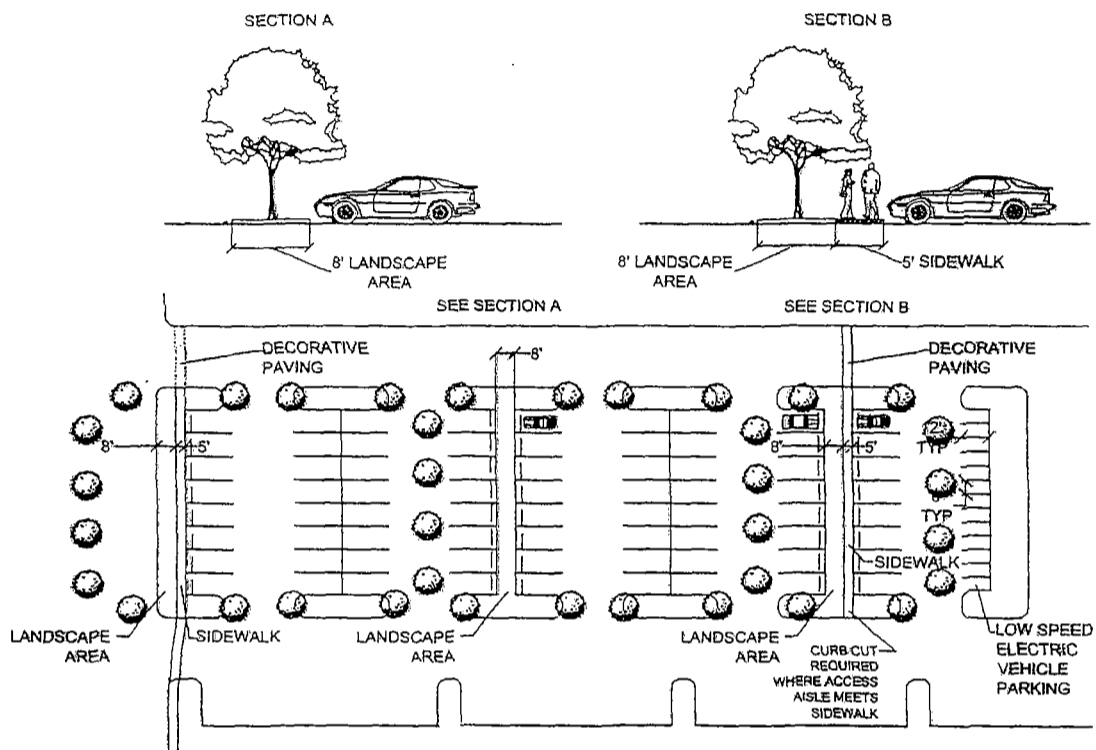
- A. The Purpose and Intent of the Parking section are to:
1. Regulate the location and appearance of surface parking areas.
 2. Provide for safe and efficient parking for vehicles and alternative transportation.
 3. Minimize the amount of impervious area by promoting smart parking strategies.

Section 2 General

- A. Design Standards
1. Surface parking, except for on-street parking, shall be completely screened from view of right-of-ways by landscaping, buildings, or structures.
 2. In addition to the tree/palm requirements of the ULDC, groundcover or small shrubs, 10 to 12 inches in height at the time of installation and shall be maintained to achieve a maximum of 18 inches in height, and planted in all terminal islands.
 3. Divider medians with a minimum landscape width of eight (8) feet shall be required in all surface parking areas with at least two (2) or more drive aisles. Divider medians shall be installed between every second pair of drive aisles and between all parking/vehicular use areas. Divider medians shall contain:
 - a. A minimum of one canopy tree for every 30 linear feet with a maximum spacing of 30 feet on center.
 - b. A minimum of one shrub for every five (5) square feet of landscape area with a minimum height of 36 inches.
 - c. Appropriate ground cover.
 - d. When divider medians are required, every second divider median shall provide a pedestrian walk with a minimum width of five feet. (Figure 8.1)
 4. On-street parking shall not be counted towards ULDC parking requirements.



Figure 8.1 Divider Medians



B. Low Speed Electric Vehicles.

1. A minimum of 5% and a maximum of 10% of the total number of ULDC required parking within each parking area shall be designated exclusively for Low Speed Electric Vehicle parking.
 - a. Areas designated for Low Speed Electric Vehicle parking shall be clearly identified with signs.
 - b. Low Speed Electric Vehicle parking shall be located within the closest proximity of the primary entrance, with exception given to handicap accessible parking.
 - c. Low Speed Electric Vehicle Parking Space Dimensions
 - (1) Minimum Width – 6 feet, not to exceed 7 feet
 - (2) Minimum Length – 12 feet, not to exceed 13 feet
 - (3) The minimum width of a drive aisle which is reserved exclusively for the use of Low Speed Electric Vehicles shall be 15 feet, not to exceed 17 feet.
 - d. All Low Speed Electric Vehicle parking shall be clustered in one area and shall be identified as Low Speed Electric Vehicle parking by signage and pavement markings.



CHAPTER 9 SIGNAGE AND SITE LIGHTING

Section 1 Signage

A. Purpose and Intent

1. The purpose and intent of this chapter is to establish standards for the placement, use, and design of signage and other advertising within the Research Park in order to maintain its intended character and aesthetic appeal.
2. The signage system is designed to create a uniform image for the overall development.
3. The Signage Standards create a signage design related to the architecture and landscape design of the site, and its scale and placement is oriented for efficient and safe vehicular and pedestrian movements.

B. General

1. Master Sign Plan

- a. A Master Sign Plan for each Pod shall be approved prior to Final DRO approval, excluding the first three buildings of Pod N which shall meet the requirements of the ULDC.
- b. The Master Sign Plan shall include the following:
 - (1) The proposed location of any signage or advertising visible from a street or public area.
 - (2) Elevations of each type of ground mounted sign.
 - (3) Elevations of each type of building mounted sign.
 - (4) A program for standards for all sign types, including, but not limited to: color size, illumination, construction details, placement, font, dimensions, and base planting details.

2. Compatibility

- a. Any freestanding permanent sign erected within the Research Park shall be compatible with the overall established theme for the Research Park.
- b. All wall signs located within the Research Park shall be compatible with the supporting structure.

3. Temporary Signs

- a. Temporary signs shall be permitted within the Research Park in accordance with the ULDC regulations and with permission of the Property Owners Association, unless otherwise authorized or required by law.



4. Location.

a. Block Style Pods

(1) All signs located within the Block Style Pods shall be building mounted.

(2) All signs located within the Town Center shall be building mounted.

(a) Entry wall signs shall be permitted at the Pod entrance and shall display the development name only.

b. The Pedestrian Mall.

(1) Freestanding signs, except for directional signs, shall not be permitted within 25 feet of the nearest property line of the Pedestrian Mall or the exterior line of the right-of-way adjacent to the Pedestrian Mall.

c. The Promenade

(1) Permanent freestanding signs shall not be permitted along the Promenade, unless approved by the Property Owners Association.

d. The BTP Natural Area

(1) Permanent freestanding signs shall not be permitted within the BTP Natural Area, unless approved by the Property Owners Association.

Section 2 Site Lighting

A. Maximum footcandles shall be established by the Illuminating Engineering Society of North America Handbook (IES Lighting Handbook).

B. Lighting styles shall be consistent or of a compatible style throughout the Research Park.



CHAPTER 10 IMPLEMENTATION

A. Application

1. These Design Standards shall be implemented at the time of Development Review Officer Final Site Plan approval and/or in conjunction with review of the building permit.

B. Conflicts

1. In the event of discrepancies or conflicts between the Design Standards and Conditions of Approval, the Conditions shall prevail. In the event of discrepancies or conflicts between the Design Standards and the ULDC, the ULDC shall prevail.
2. The Executive Director of Palm Beach County Planning, Zoning, and Building or his/her assignee, shall rule on any conflicts, discrepancies, or interpretations.

C. Amendments

1. The Design Standards are subject to a condition of approval in the Development Order. Amendments to the Design Standards may be requested by a Development Order Amendment, subject to Article 2.G. of the ULDC.

